



TECBOR® BOARDS: • METAL STRUCTURE: COLUMNS AND BEAMS • CONCRETE STRUCTURAL ELEMENTS: COLUMNS AND SLABS • CABLE TRAY • VENTILATION DUCTS • NON STRUCTURAL ELEMENTS. WALLS • SUSPENDED CEILINGS AND SLAB PROTECTION • CURTAIN WALLS • TUNNELS



IBERIA · LATAM · MIDDLE EAST · NORTH AFRICA · TURKEY



This catalogue is for commercial purposes only and represents no type of validation of certifications. Listed tests are currently in force and as a result, we decline all liability as a result of an improper use of the products.



BUILDING SOLUTIONS FOR YOUR SAFETY

Tecresa Protección Pasiva[®], a Spanish company established on 24 July 1998, has been part of the **Mercor**[®] Group since 19 February 2008. It was originally created to offer, both the national and international market, cutting edge comprehensive solutions for passive protection against fire, focusing on two areas: Smoke vents and materials resistance with products made on our premises, such as the **Tecwool**[®] mortar or **Tecbor**[®] boards.

Our main objective is to meet the needs of the current, competitive and ever-changing market providing not only solutions to the development and marketing of fire protection materials but also a wider approach to enable customers to optimise their management, which is a key to competitiveness.

In recent years, **mercortecresa**[®] has consolidated its leadership in the sector due to its commitment, technology and development of fire prevention systems.

The company policy is based on a continuous improvement of the production capacity, with a permanent focus on service quality and customer satisfaction. Thus, it has been the first quality certified company in the passive protection sector in compliance with standard ISO 9001:2008 and ISO 14001:2004 by Applus. Regarding occupational risk prevention, it has complied with standard OHSAS 18001:2007.

Mercortecresa[®] is in continuous evolution and development, striving to improve every day the service we offer to our customers.

LEGEND



Fire protection



Thermal insulation



Acoustic absorption



**Fire protection for industrial
appliances and tunnels**



Reference works

	TECBOR® PRESENTATION	7
	TECHNICAL CHARACTERISTICS AND SPECIFICATIONS	9
	SOLUTIONS	10
	1 - Metal structure	10
	2 - Concrete structural elements	18
	3 - Cable trays	24
	4 - Ventilation and Smoke extraction ducts	26
	5 - Non-structural elements. Walls	30
	6 - Curtain walls	40
	7 - Tunnels	46
	8 - Tecbor® Y firewall strips	56
	REFERENCE WORK	60

TECBOR®





TECBOR®

GENERAL CHARACTERISTICS OF OUR BOARDS

COMPOSITION

Tecbor® boards are rigid fire protection panels made of magnesium oxide, silicates, and other additives, finished with a fibreglass mesh on both sides.

TESTS

Mercor tecsasa® is constantly evolving and adapting to the regulatory changes by developing new tests, conducted in official laboratories accredited by ENAC or a similar international body and under UNE EN, ASTM standards. Given our concern to make **Tecbor®** an integral solution, we conduct real-scale tests in tunnels, hydrocarbon curve tests, RWS curve tests or tests under the American UL standard.

FIRE REACTION

Tecbor® is classified as A1 (non combustible) pursuant to European Standard EN 13501-1.

TRACEABILITY

All of our products undergo internal quality control procedures to guarantee the history, location and path of our batches.

QUALITY

Tecbor® boards bear the CE Mark (ETA 18/1017) pursuant to the specifications of the ETAG 018-4 Guide approved by EOTA.

Commitment to and effort in the creation of a market leading product, certified by Applus pursuant to standard ISO 9001.

HEALTH AND SAFETY

Tecbor® boards do not contain hazardous substances, according to the Commission's Database DS041/051.

TECHNICAL ASSISTANCE

Our commercial department, through its technicians, offers consulting personalised attention both for constructive solutions and building regulations.

APPLICATION

We seek to make our products easy and quick to assemble, thus delivering the most competitive solutions in the market.

GLOBALISATION

Directly and through the **Mercor® Group** enterprises, **Tecsasa®** markets its products all over the world, seeking to be the point of reference in passive fire protection.

TECBOR® BOARDS*



Tecbor® boards are presented in two formats with different finish:

1. **Squared edge:** this finish is suitable for constructive solutions where 90° boards meet, as in the case of ducts, tunnels, fire belts barriers, etc.

2. **Tapered edge:** is a unique board with its two long edges tapered, what offers a great finish for solutions such as suspended ceilings, partition walls, wall cladding, etc.

TAPERED EDGE PROVIDES CERTAIN ADVANTAGES:*

- Aesthetic finish. Meeting joints are concealed with the tapered edges, giving a suitable aesthetic appearance for suspended ceilings, partition walls, wall cladding, etc.
- Greater resistance to fissures. Risk of fissures is reduced by the placement of cover strip.
- Reduction of workability. Faster speed in the finish process.

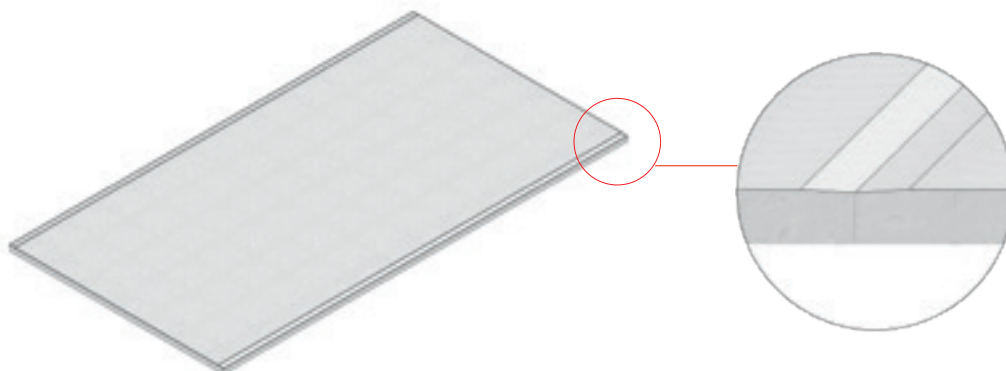

TECHNICAL CHARACTERISTICS AND SPECIFICATIONS

SPECIFICATIONS	TECBOR®	NORMATIVE
Composition	Magnesium oxide and other additives	-
Fire performance	Non-combustible Euroclass A1	UNE - EN 13501-1:2002
Dry density (40 °C)	900 kg/m ³ ±10%	UNE - EN 12467
Density (23 °C y 50% HR)	925 kg/m ³ ±10%	UNE - EN 12467
Thermal conductivity	0,31 W/mk	UNE - EN 12664
Alkalinity pH	8-10	UNE - EN 13468
Water absorption capacity	4,5 kg/m ²	EN 1609
Steam permeability	3 x 10 ⁻⁹ (Kg/m ² sPa)	UNE - EN ISO 12572
Lengthwise tolerance	± 5 mm	UNE - EN 12467
Widewise tolerance	± 3 mm	UNE - EN 12467
Thermal expansion (20-100 °C)	3	UNE - EN ISO 10.545-8/97
Tolerance to thickness	+2 mm -1 mm	UNE - EN 12467
Edge straightness	Level I - 0,1%	UNE - EN 12467
Organic matter content	3,3%	UNE 103 204/93
Resistance to water erosion	R _L < 0,75	UNE - EN 12467
Modulus of elasticity (MPa)	475	UNE - EN 12089 UNE - EN 310
Flexural strength MOR (MPa)	4,74	EN- 12467
Tensile strength perpendicular to fibre (MPa)	1,47	EN - 1607
Compressive strength (MPa)	9,61	EN - 826
Dimensional stability	≤ 0,25%	UNE - EN 326-1
Tensile strength paralell to fibre (MPa)	0,99	EN 1608
Microbial proliferation	No	EN 13403
Life	25 years Z ₂ (indoors)	ETA 18/1017

TECBOR®



Technical characteristics and specifications

1. STEEL STRUCTURE

Steel structures are used for building purposes worldwide. One of the main advantages is that they have great resistance per weight unit, which provides them with huge versatility and the possibility of creating complex yet light structures.

However, the thermal conductivity of steel represents a disadvantage. Therefore, in the event of a fire, the gradual increase in temperature plus steel high heat transmission result in a substantial reduction of the structure's bearing capacity and mechanical resistance. The resistance and elastic limit are modified above 250°C, and above roughly 500°C the drop in resistance is significant enough not to support its design capacity.

mercortecresa[®] has conducted numerous tests with **Tecbor**[®] according to **UNE EN 13381-4**, standard, in which is determined the contribution of fire protection of the board when we protect steel structural elements, either on beams, columns or bearing elements.

Tecbor[®] has been tested to cover a great variety of steel profiles characterised by their section factors. Likewise, it has been tested for several standard specified design temperatures.

TECBOR® BOX SECTION FACTOR

The data of this table are featured in the assessment report of file **058417-002**.
Table valid for a steel design temperature of 300 °C according to **UNE ENV 13381-4**.

OUR METALLIC STRUCTURE PROTECTION TEST FOR A CRITICAL TEMPERATURE OF 300 °C. TECBOR BOARD THICKNESSES (mm).

Mass	THICKNESS (mm)								
	R-15 15 min	R-20 20 min	R-30 30 min	R-45 45 min	R-60 60 min	R-90 90 min	R-120 120 min	R-180 180 min	R-240 240 min
58	9,5	9,5	9,5	9,5	9,5	9,5	13,3	23,7	34,0
70	9,5	9,5	9,5	9,5	9,5	10,8	16,2	27,0	37,8
80	9,5	9,5	9,5	9,5	9,5	12,4	18,0	29,1	40,2
90	9,5	9,5	9,5	9,5	9,5	13,7	19,4	30,8	42,2
100	9,5	9,5	9,5	9,5	9,5	14,8	20,6	32,3	43,9
110	9,5	9,5	9,5	9,5	9,9	15,8	21,7	33,5	45,3
120	9,5	9,5	9,5	9,5	10,6	16,6	22,6	34,5	46,5
130	9,5	9,5	9,5	9,5	11,3	17,3	23,3	35,4	47,5
140	9,5	9,5	9,5	9,5	11,8	17,9	24,0	36,2	48,4
150	9,5	9,5	9,5	9,5	12,3	18,5	24,6	36,9	49,2
160	9,5	9,5	9,5	9,6	12,7	18,9	25,1	37,5	49,9
170	9,5	9,5	9,5	10,0	13,1	19,4	25,6	38,1	50,6
180	9,5	9,5	9,5	10,3	13,5	19,8	26,0	38,6	51,2
190	9,5	9,5	9,5	10,6	13,8	20,1	26,4	39,1	51,7
200	9,5	9,5	9,5	10,9	14,1	20,4	26,8	39,5	52,5
210	9,5	9,5	9,5	11,2	14,4	20,7	27,1	39,8	52,6
220	9,5	9,5	9,5	11,4	14,6	21,0	27,4	40,2	53,0
230	9,5	9,5	9,5	11,6	14,8	21,2	27,7	40,5	53,4
240	9,5	9,5	9,5	11,8	15,0	21,5	27,9	40,8	53,7
250	9,5	9,5	9,5	12,0	15,2	21,7	28,1	41,1	54,0
260	9,5	9,5	9,5	12,1	15,4	21,9	28,4	41,3	54,3
270	9,5	9,5	9,5	12,3	15,6	22,1	28,6	41,6	54,6
280	9,5	9,5	9,5	12,4	15,7	22,2	28,7	41,8	54,8
290	9,5	9,5	9,5	12,6	15,9	22,4	28,9	42,0	55,1
300	9,5	9,5	9,5	12,7	16,0	22,5	29,1	42,2	55,3
310	9,5	9,5	9,6	12,8	16,1	22,7	29,2	42,4	55,5
320	9,5	9,5	9,7	12,9	16,2	22,8	29,4	42,5	55,7
330	9,5	9,5	9,8	13,1	16,3	22,9	29,5	42,7	55,9
340	9,5	9,5	9,9	13,2	16,5	23,0	29,6	42,8	56,0
350	9,5	9,5	9,9	13,2	16,6	23,2	29,8	43,0	56,2
360	9,5	9,5	10,0	13,3	16,6	23,3	29,9	43,1	56,4
370	9,5	9,5	10,1	13,4	16,7	23,4	30,0	43,3	56,5
380	9,5	9,5	10,2	13,5	16,8	23,5	30,1	43,4	56,6
390	9,5	9,5	10,3	13,6	16,9	23,6	30,2	43,5	56,8
400	9,5	9,5	10,3	13,7	17,0	23,6	30,3	43,6	56,9
410	9,5	9,5	10,4	13,7	17,1	23,7	30,4	43,7	57,0
420	9,5	9,5	10,5	13,8	17,1	23,8	30,5	43,8	57,1
430	9,5	9,5	10,5	13,9	17,2	23,9	30,6	43,9	57,3
440	9,5	9,5	10,6	13,9	17,3	23,9	30,6	44,0	57,4
498	9,5	9,5	10,9	14,2	17,6	24,3	31,0	44,5	57,9



1.1 SYSTEM FOR GUIDE RUNNING LENGTHWISE TO THE SECTION. PILARS

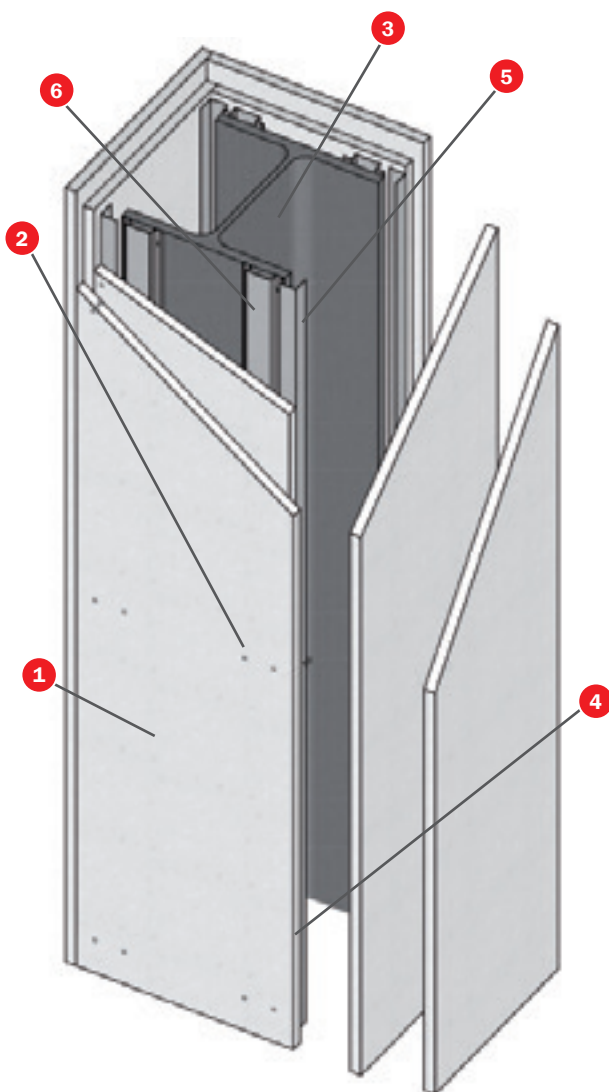

TEST

Standard: UNE EN 13381-4

Laboratory: TECNALIA

Test N°: 058417-002

SOLUTION

- 1 Tecbor® Boards
- 2 Self-tapping screw (size according to board)
- 3 Steel columns
- 4 Tecbor® joint paste
- 5 30x30x0,6 mm angle section
- 6 45x15x0,6 mm omega

DESCRIPTION OF ASSEMBLY

Fix 45x15x0,6 mm omega profiles to the outer side of the metal profile's flange to be protected with steel nails every 725 mm.

Fix 30x30x0,6 mm lower angle section to the Tecbor® board strips and these onto the omega profiles and onto the angle anchored to the slabs with self-tapping screws every 250 mm. Assemble the strips

Use Tecbor® joint paste in screw heads and between boards.

NOTE: If the protection procedure comprises Tecbor® boards with a thickness equal to or greater than 30 mm, they may be joined without auxiliaries using 5 x 80 mm screws at intervals of 250 mm.

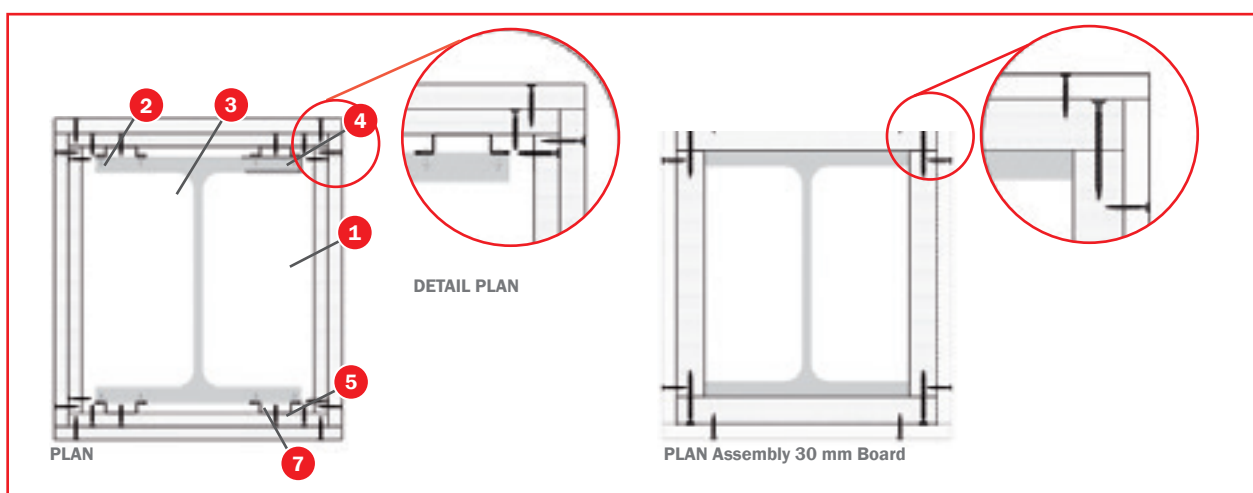

1.2 SYSTEM FOR GUIDE RUNNING LENGTHWISE TO THE SECTION. BEAMS

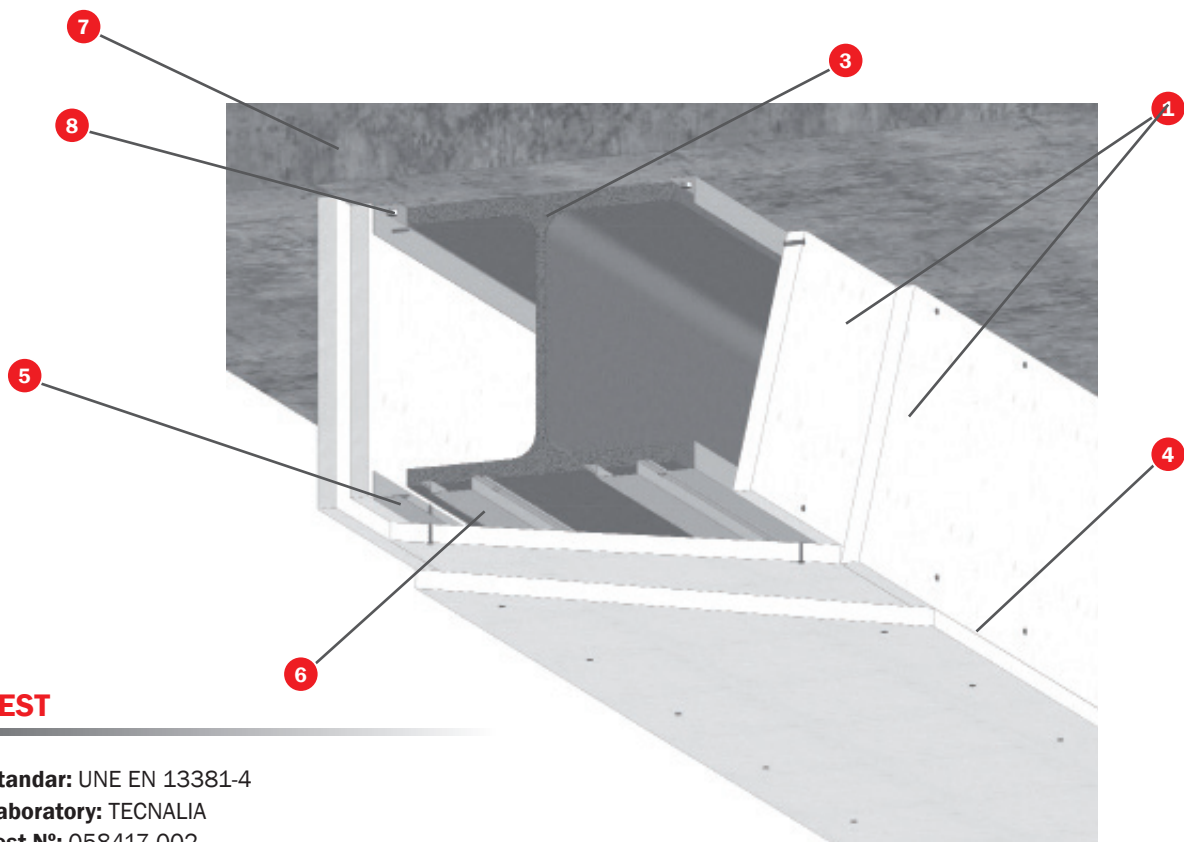

TEST

Standar: UNE EN 13381-4

Laboratory: TECNALIA

Test N°: 058417-002

SOLUTION

- 1 Tecbor® boards
- 2 Self-tapping screw (size according to board)
- 3 Steel beam
- 4 Tecbor® joint paste
- 5 30x30x0,6 mm angle section
- 6 45x15x0,6 mm omega
- 7 Slab
- 8 6x60 mm metal plug

DESCRIPTION OF ASSEMBLY

Fix 45x15x0.6 mm omega profiles to the outer side of the metal profile's flange to be protected with steel nails every 725 mm.

Fix 30x30x0.6 mm lower angle section to the Tecbor® board strips and these onto the omega profiles and onto the angle anchored to the slabs with self-tapping screws every 250 mm.

Use Tecbor® joint paste in screw heads and between boards..

NOTE: If the protection procedure comprises Tecbor® boards with a thickness equal to or greater than 30 mm, they may be joined without auxiliaries using 5 x 80 mm screws at intervals of 250 mm.

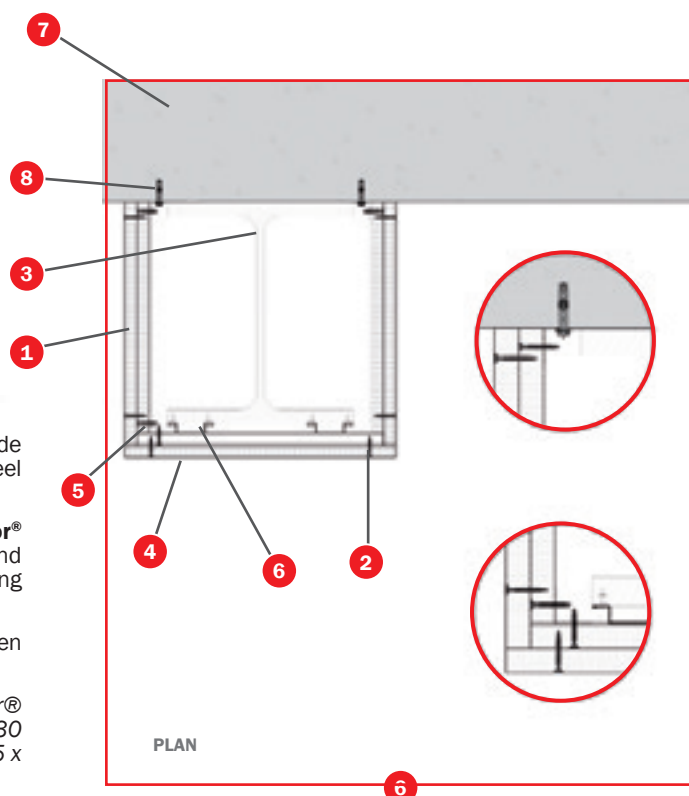

TECBOR®



Metal structure

1.3 SYSTEM FOR GUIDE TO FORM A RING

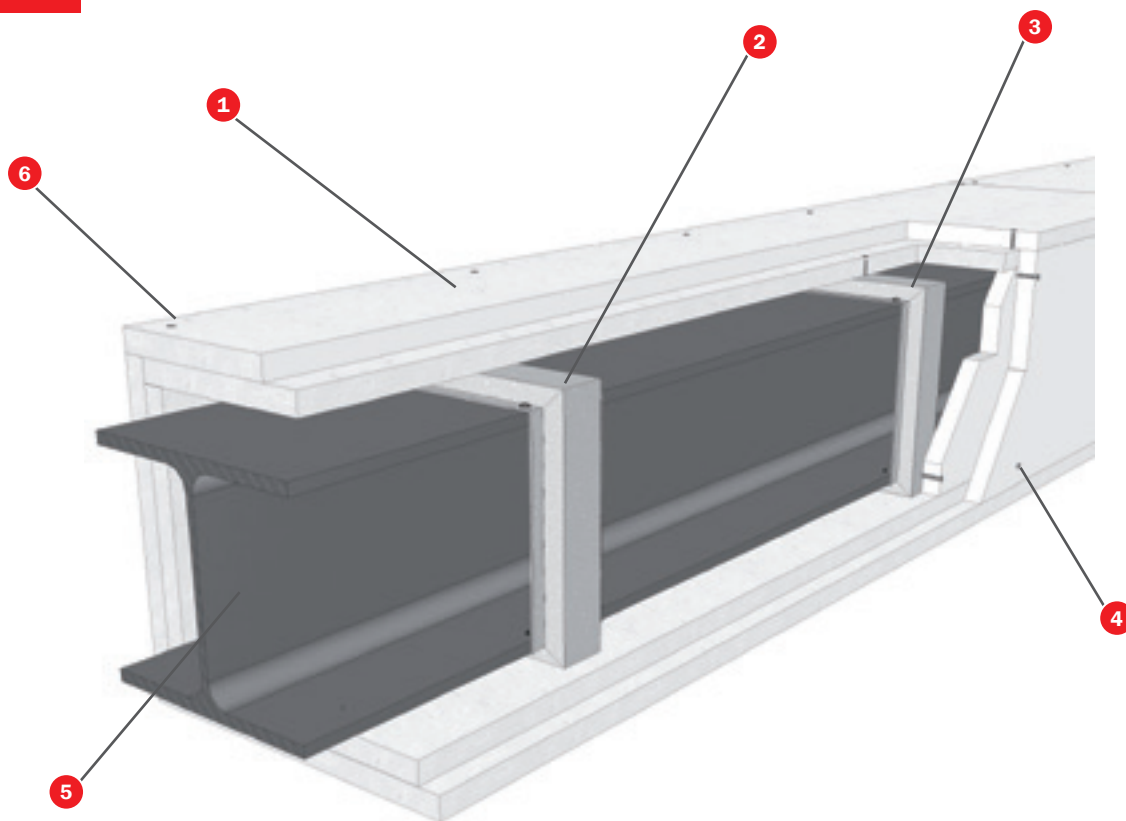

TEST

Standard: UNE EN 13381-4

Laboratory: TECNALIA

Test N°: 058417-002

SOLUTION

- 1 Tecbor® Boards
- 2 45x15x0,6 mm omega
- 3 X-dnl type nail or similar
- 4 Self-tapping screw (size according to board)
- 5 Profile
- 6 Tecbor® joint paste

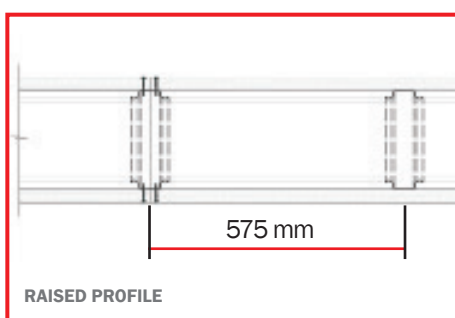

DESCRIPTION OF ASSEMBLY

Attach the 45 x 15 x 0.6 mm omega profiles to the outer side of the flange of the metal profile to be protected using steel nails, and form a ring around it. The rings will be separated at intervals of a maximum of 575 mm. They will be placed in such a way that the horizontal joints between plates overlap on an omega profile.

Attach the anchored **Tecbor®** plates to the omega profiles using self-tapping screws every 250 mm

Use **Tecbor® joint paste** in screw heads and between boards.

SECTION PROFILE

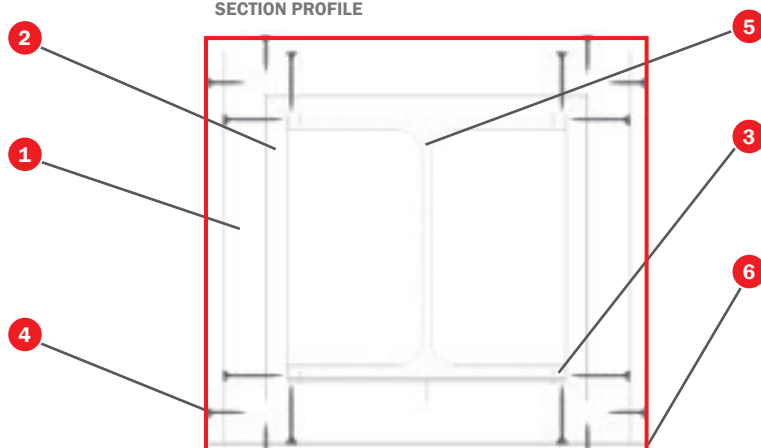

1.4 TECBOR CLIP SYSTEM

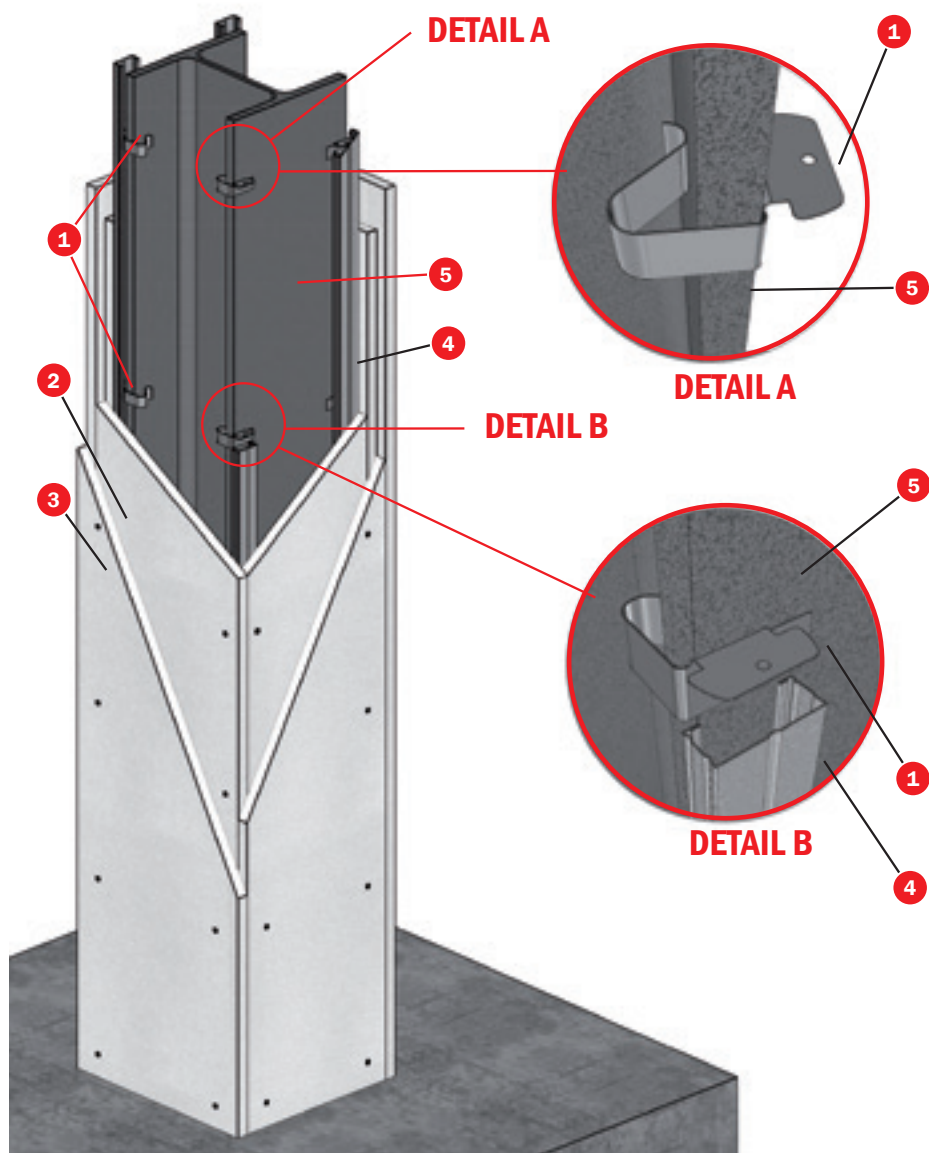

TECBOR®



Metal structure

15

TEST

Standard: UNE EN 13381-4

Laboratory: TECNALIA

Test N°: 058417-002

SOLUTION

- 1 Clip Tecbor®
- 2 Tecbor® board
- 3 Self-tapping screw (size according to board)
- 4 Profile TC 45x18x0,6 mm
- 5 Beam or type column

DESCRIPTION OF ASSEMBLY

Attach the Tecbor® clip to the outer side of the metal profiles to be protected, separated at intervals of no more than 500 mm.

Attach the 45 x 18 x 0.6 mm TC roof profiles to the Tecbor® clip by pressure.

Attach the anchored Tecbor® plates to the TC profiles using self-tapping screws every 250 mm

Use Tecbor® joint paste in screw heads and between boards.

1.5 PLATE CLAMPING SYSTEM

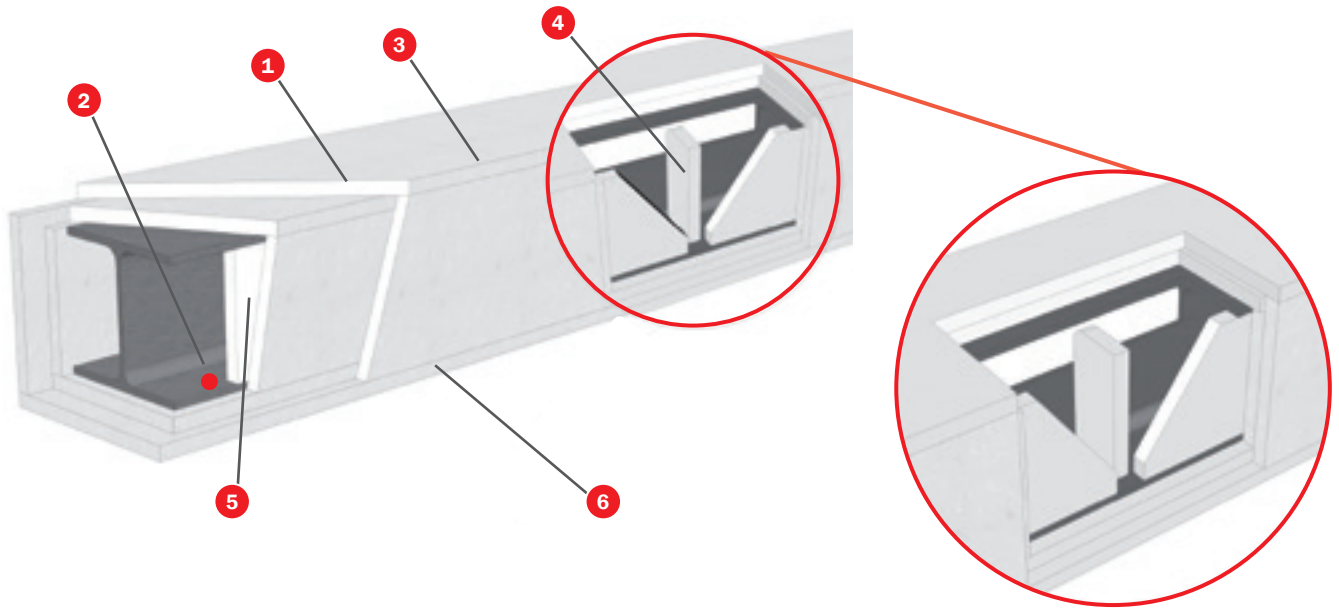

TEST

Standard: UNE EN 13381-4

Laboratory: TECNALIA

Test N°: 058417-002

SOLUTION

- 1 Tecbor® boards
- 2 Profile
- 3 Self-tapping screw (size according to board)
- 4 Stiffener Tecbor® 20 mm
- 5 Tecbor® 20 mm board
- 6 Tecbor® joint paste

DESCRIPTION OF ASSEMBLY

Cut stiffeners with **Tecbor®** 20 mm boards, adapted to the measurements of the metal profile to be protected. Insert them perpendicular to the axis of the profile at intervals of no more than 575 mm.

Cut **Tecbor®** board strips of the measurement between the flanges of the metal profile to be protected. Attach these strips to the stiffeners using self-tapping screws, so that the joint between the plates overlaps on a support stiffener.

Attach the **Tecbor®** boards of a thickness equal to or greater than 20 mm to each other and anchored onto the plate stiffeners using self-tapping screws every 250 mm.

Use **Tecbor® joint paste** in screw heads and between boards.

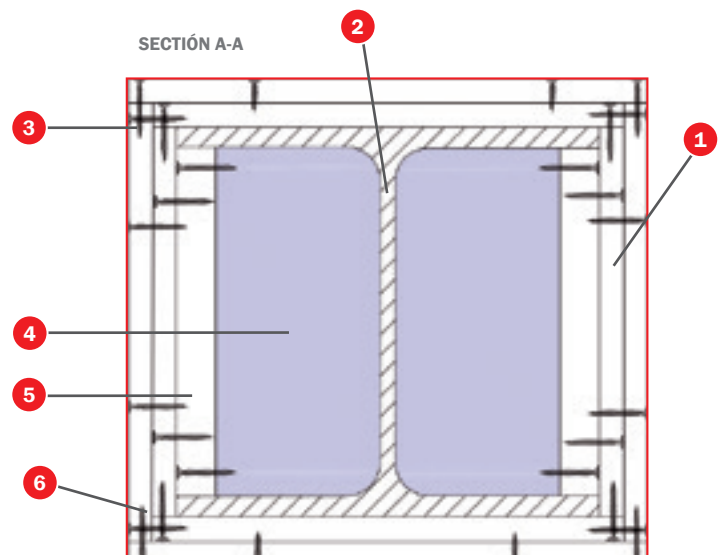
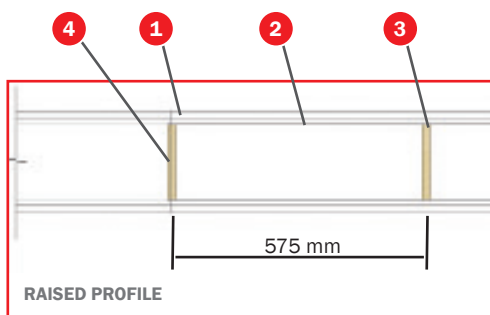

1.6 FIXING SYSTEM USING BRACKETS

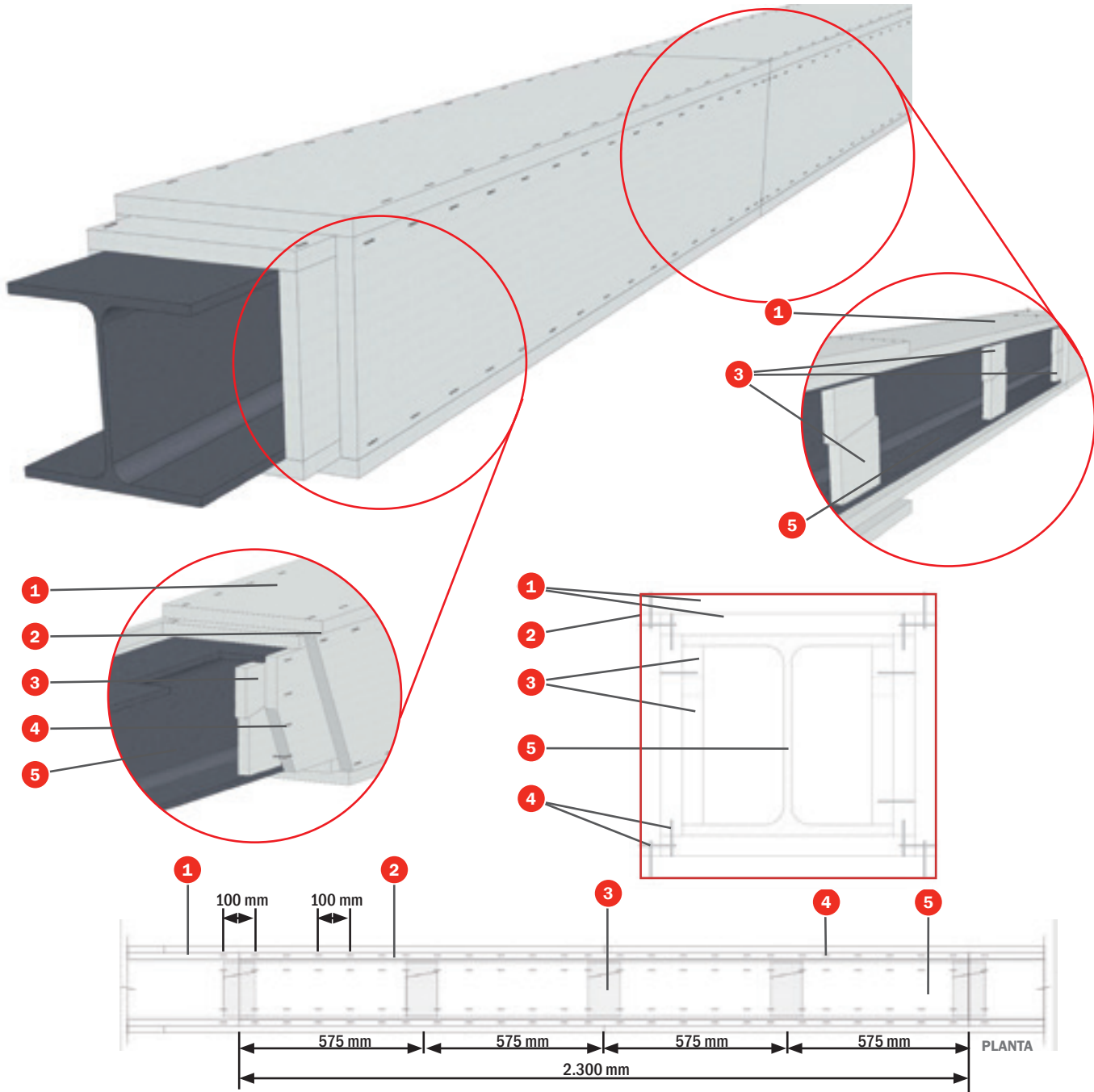

TEST

Standard: UNE EN 13381-4
Laboratory: TECNALIA
Test N°: 058417-002

SOLUTION

- 1 Tecbor® boards
- 2 Tecbor® joint paste
- 3 Support stiffener for 20 mm Tecbor® board
- 4 Fixing bracket (dimensions according to board)
- 5 Steel profile

DESCRIPTION OF ASSEMBLY

Cut support stiffeners with **Tecbor®** boards of 20 mm, of 100 mm in width and adapted to the measurements of the metal profile to be protected. Insert them using a wedge as indicated in the detailed plans at intervals of no more than 600 mm.

Attach the **Tecbor®** side plates to the support stiffeners so that the joints between the plates overlap on a support stiffener. These **Tecbor®** side plates will be attached using metal brackets separated at intervals of 50 mm between plates.

A support stiffener will only be attached to the **Tecbor®** side plates for the beams, using metal brackets, on the lower face of the profile to be protected and formed with **Tecbor®** boards of 20 mm and 100 mm in width.

Attach the lower **Tecbor®** boards to the side ones and to the lower support stiffeners using metal brackets separated at intervals of no more than 100 mm.

Brackets of a length that is equal to or greater than the total thickness of the plates to be joined will be used; their minimum dimensions will be 35 x 10.6 x 1.6 mm.

TECBOR®



Metal structure

2. CONCRETE STRUCTURAL ELEMENTS

Despite its lack of combustibility and low thermal conductivity, the concrete experiences during the fire the formation of porous pressures and ductile internal tensions which generate explosives splinters. This results in the loss of sections and the exposure of the reinforcement steel to extremely high temperatures.

Furthermore, due to the warming, in particular to temperatures higher than 300 °C, the concrete losses its resistance. These problems can be faced through the passive fire protection of concrete structural elements.

The fire protection of the concrete structural elements is used to prevent the chip explosion, which a higher degree of concrete is much more sensitive to.

Overall, the passive fire protection has become a priority issue anywhere where a combination with the following aspects is presented: chip explosion prevention; reinforcement and steel protection; so it doesn't exceed critical temperatures, protection so that the concrete doesn't exceed excessive temperatures.

2.1 PROTECTION OF BEAMS AND CONCRETE SLABS TECBOR® R-30 - R-240

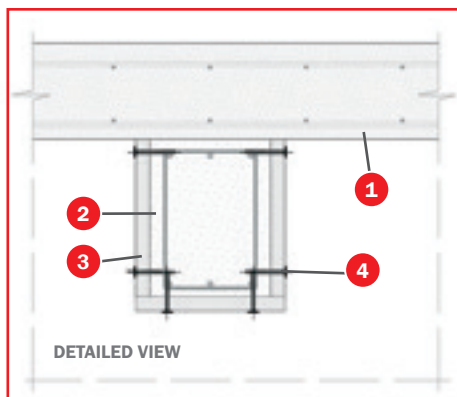
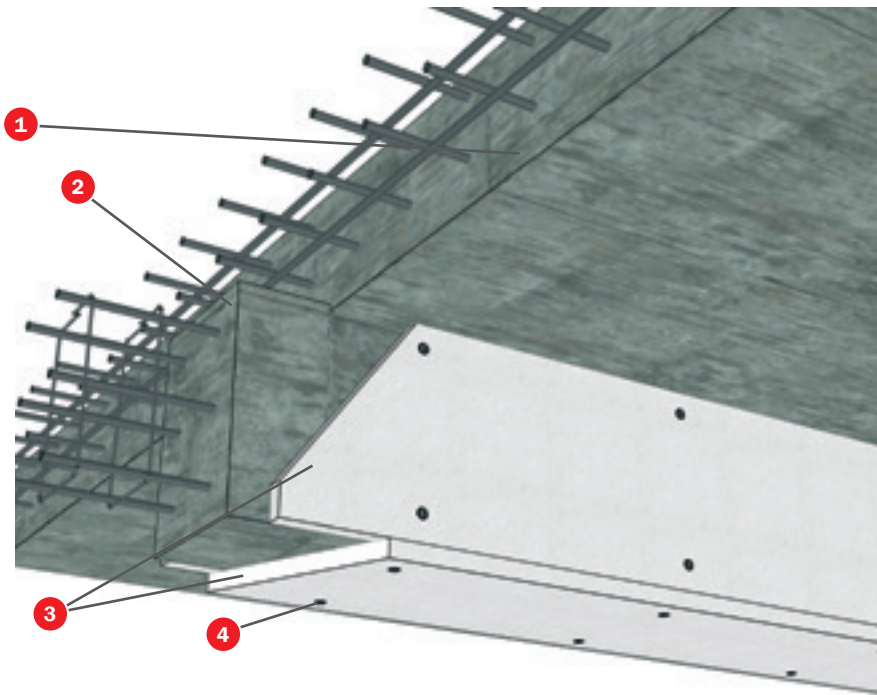

TEST

Standard: UNE EN 13381-3.

Laboratory: APPLUS.

Test N°: 12-3550-541 M-1 and 12-3550-656.

SOLUTION

- 1 Slab
- 2 Concrete beam
- 3 Tecbor® boards
- 4 DBZ 6/35 metal anchors

DESCRIPTION OF ASSEMBLY

As minimum and maximum thickness were tested depending on the requested REI, we will need a determined number of layers to be installed. The boards will be directly fixed to the concrete with metal impact anchors Hilti DBZ type. Boards layout will be butt joint with no need of bonding paste. In the case where the gap between joints is bigger than 3 mm, Tecsel® mastic will be needed.

TECBOR®



Concrete structural elements



SPALLING EFFECT

This explosion is the violent break of the concrete layers or pieces of the surface of a structural element when exposed to a fast increase of temperatures, as it happens during a fire.

It usually takes place during the first 20 or 30 minutes in a conflagration. Many materials, (for example: permeability, saturation level, size and type of aggregate, presence of breakage and reinforcement); the geometrical shapes (as the section size) and the environment (resistance level, or heating and profile rate), have been factors influencing the splinters during a fire, as it has been identified from the researches.

The main factors which impact on the splinters are: the rate of warning (mainly over 2° or 3° C/minute), permeability of the material, degree of saturation of the pores (mainly over 2 or 3% of the moisture content by weight of the concrete), presence of reinforcement and level of external applied resistance.

Concrete's low permeability shows a greater tendency to splinter than one with concrete's average resistance, despite its greater resistance to tension.

This is because greater pressures on the pores are formed during the heating, due to the low permeability of the material. Furthermore, the highest pressure point on the pores happens closer to the surface for concrete.

PROTECTION WITH TECBOR® BOARDS

Fire resistance of concrete structural elements varies according to its density, moisture content, composition, size factors and distance to the shaft edge of the metal framework.

With the calculation methods contained in ENV 1992-1-2 1955 standard, Eurocode 2 part 1-2 can be designed the concrete structural elements with the required bearing and compartment capacity for normalized thermal action.

Nevertheless, in order to improve the resistance capacity of the concrete, the **Tecbor®** boards offer a very effective and economic technical solution, increasing the fire resistance of the concrete structural elements.

EUROCODE 2, establishes the possibility of using protection and improvement systems with the

corresponding test to determine both the equivalent thickness of the material and its capacity to remain cohesive and consistent with the slab.

CTE in its annex C also collects these specifications.

Tecbor® boards have their corresponding test according to UNE ENV 13381-3:2004 standard. The equivalent factors in concrete of the **Tecbor®** boards for different fire resistances have been tested through this test. The thicknesses to be applied are determined according to these factors.

Mercor tectura® has carried out the study to calculate the minimum thickness of the **Tecbor®** boards to obtain different critic T at different coating thickness both on slabs.

Study to find the minimum thickness of the Tecbor® boards to obtain certain critic T at different coating thickness on concrete beams

Data have been obtained from the test results shown in the 12/3550-656, 12/3550-200, 12/3550-201 reports and assuming a linear correlation between the protection thickness of **Tecbor®** and its fire performance.

Boxes without numeric value indicate that the corresponding value is higher than the maximum tested value (40 mm).

Boxes with value 0 indicate that it is not necessary the application of protection due to the concrete beam's own fire resistance.

	350 °C	400 °C	450 °C	500 °C	550 °C	600 °C	650 °C
Coating thickness "g" (mm)	Minimum protection thickness (mm) for R30						
≥5	0	0	0	0	0	0	0

	350 °C	400 °C	450 °C	500 °C	550 °C	600 °C	650 °C
Coating thickness "g" (mm)	Minimum thickness of protection (mm) for R60						
5-9	10	0	0	0	0	0	0
≥10	0	0	0	0	0	0	0

	350 °C	400 °C	450 °C	500 °C	550 °C	600 °C	650 °C
Coating thickness "g" (mm)	Minimum thickness of protection (mm) for R90						
5-9	18	13	10	10	10	0	0
10-14	11	10	10	0	0	0	0
15-19	10	0	0	0	0	0	0
≥20	0	0	0	0	0	0	0

	350 °C	400 °C	450 °C	500 °C	550 °C	600 °C	650 °C
Coating thickness "g" (mm)	Minimum thickness of protection (mm) for R120						
5-9	28	26	23	21	18	16	16
10-14	24	21	17	14	11	10	10
15-19	17	12	10	10	0	0	0
20-24	11	10	0	0	0	0	0
25-29	10	10	0	0	0	0	0
30-34	10	10	0	0	0	0	0
35-39	10	10	0	0	0	0	0
40-44	10	0	0	0	0	0	0
45-49	10	0	0	0	0	0	0
50-54	10	0	0	0	0	0	0
55-59	10	0	0	0	0	0	0
≥60	0	0	0	0	0	0	0

R180 and R240 tables have been obtained with data only from the 12/3550-200 maximum thickness test.

	350 °C	400 °C	450 °C	500 °C	550 °C	600 °C	650 °C
Coating thickness "g" (mm)	Minimum thickness of protection (mm) for R180						
≥5	40	40	40	40	40	40	40

	350 °C	400 °C	450 °C	500 °C	550 °C	600 °C	650 °C
Coating thickness "g" (mm)	Minimum thickness of protection (mm) for R240						
5-9	-	-	-	-	-	40	40
10-14	-	-	-	-	40	40	40
15-19	-	-	-	40	40	40	40
20-24	-	-	40	40	40	40	40
25-29	-	40	40	40	40	40	40
30-34	-	40	40	40	40	40	40
35-39	-	40	40	40	40	40	40
40-44	-	40	40	40	40	40	40
45-49	-	40	40	40	40	40	40
≥50	40	40	40	40	40	40	40



Study to find the minimum thickness of the Tecbor® boards to obtain certain critical T at different coating thickness on concrete slabs

Data have been obtained from the test results shown in the 12/3550-541, 12/3550-167, 12/3550-199 reports and assuming a linear correlation between the protection thickness of Tecbor® and its fire performance.

Boxes without numeric value indicate that the corresponding value is higher than the maximum tested value (40 mm).

Boxes with value 0 indicate that it is not necessary the application of protection due to the concrete slab's own fire resistance.

	350 °C	400 °C	450 °C	500 °C	550 °C	600 °C	650 °C
Coating thickness "g" (mm)	Espesor mínimo de protección (mm) para R30						
≥5	0	0	0	0	0	0	0

	350 °C	400 °C	450 °C	500 °C	550 °C	600 °C	650 °C
Coating thickness "g" (mm)	Espesor mínimo de protección (mm) para R60						
≥5	0	0	0	0	0	0	0

	350 °C	400 °C	450 °C	500 °C	550 °C	600 °C	650 °C
Coating thickness "g" (mm)	Espesor mínimo de protección (mm) para R90						
5-9	27	24	22	19	17	14	12
10-14	21	18	15	11	10	10	10
15-19	14	10	10	0	0	0	0
20-24	10	0	0	0	0	0	0
>25	0	0	0	0	0	0	0

	350 °C	400 °C	450 °C	500 °C	550 °C	600 °C	650 °C
Coating thickness "g" (mm)	Minimum coating thickness (mm) for R120						
5-9	30	28	26	24	22	20	17
10-14	27	25	22	20	17	15	13
15-19	24	21	18	15	12	10	10
20-24	22	18	15	11	10	10	10
25-29	19	15	11	10	10	0	0
30-34	16	12	10	10	0	0	0
35-39	10	10	10	0	0	0	0
40-44	10	10	0	0	0	0	0
≥45	0	0	0	0	0	0	0



	350 °C	400 °C	450 °C	500 °C	550 °C	600 °C	650 °C
Coating thickness "g" (mm)	Minimum thickness of protection (mm) for R180						
5-9	-	-	-	-	-	-	36
10-14	-	-	-	38	34	29	25
15-19	-	37	33	29	25	22	18
20-24	36	32	28	24	20	16	12
25-29	33	29	25	21	17	13	10
30-34	30	26	22	17	13	10	10
35-39	27	22	18	14	10	10	10
40-44	23	18	14	10	10	0	0
45-49	20	15	10	10	0	0	0
50-54	17	11	10	10	0	0	0
55-59	14	10	10	0	0	0	0
60-64	10	10	0	0	0	0	0
65-69	10	0	0	0	0	0	0
≥70	0	0	0	0	0	0	0

	350 °C	400 °C	450 °C	500 °C	550 °C	600 °C	650 °C
Coating thickness "g" (mm)	Minimum thickness of protection (mm) for R240						
5-9	-	-	-	-	-	-	-
10-14	-	-	-	-	-	-	-
15-19	-	-	-	-	-	-	-
20-24	-	-	-	-	-	-	38
25-29	-	-	-	-	-	38	28
30-34	-	-	-	-	38	28	19
35-39	-	-	-	38	29	19	10
40-44	-	-	38	29	19	10	10
45-49	-	40	31	21	12	10	0
50-54	-	33	23	14	10	0	0
55-59	36	27	18	10	0	0	0
60-64	30	21	12	10	0	0	0
65-69	25	15	10	0	0	0	0
70-74	20	11	10	0	0	0	0
75	15	10	0	0	0	0	0

Note: values for R240 cannot be found for depths greater than 75 mm, as there is no temperature value at greater depths since the maximum depth at which the thermocouples must be placed is 75 mm (s. UNE EN 13381-3:2004)



3. CABLE TRAY

Protecting the wiring adequately will be crucial when electrical supply systems must be kept in optimal running conditions during fires. In tunnels, heavy traffic buildings or high-rises, it is of paramount importance to perform orderly evacuations while basic systems keep running.

Tecbor[®] 40 mm has been tested covering a cable tray from different sections and evaluated according to UNE EN 1363-1 general requirements, following the heating curve defined by UL 1709 standard. Electric conductivity, short-circuit between cables and earth fault have been also added.

Facilities may be accessed through inspection hatches. Likewise, **Tecsel**[®] **Grids** allowing for ventilation and sealing the hole in case of fire have been tested. *(For additional information, please contact our Sales Department.)*

3.1 CABLE PROTECTION TECBOR® 40 - EI-120

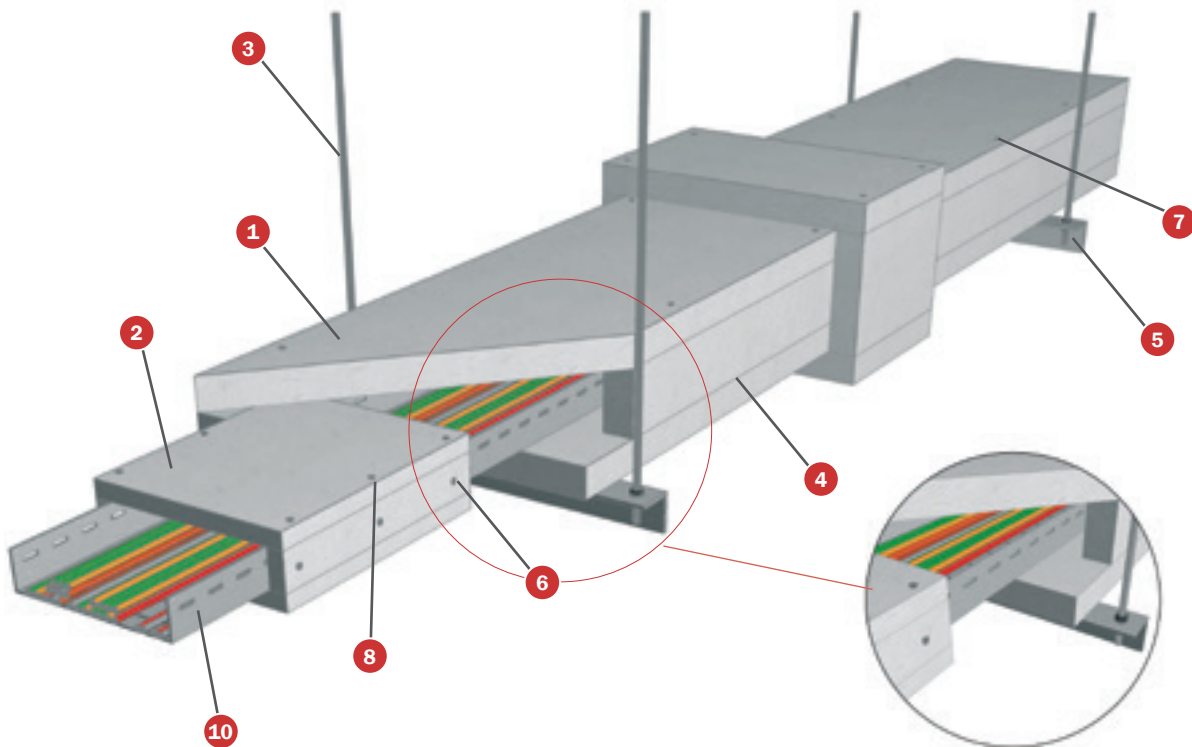

TEST

Standard: UNE EN 1363-1.
Heating Curve UL 1709
Laboratory: CIDEMCO
N° Test: 25417

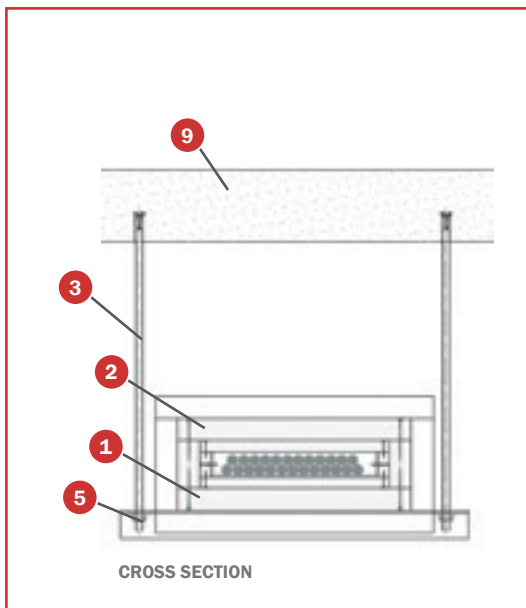

SOLUTION

- 1 Tecbor® 40 mm boards
- 2 Tecbor® 20 mm boards
- 3 M12 rod
- 4 Tecbor® joint paste ready to use
- 5 50x50x5 mm angle section every 1000 mm
- 6 3,5x45 mm self-drilling screw
- 7 5,2x80 mm self-tapping screw
- 8 3,5x45 mm self-tapping screw
- 9 Slab
- 10 Cable tray

DESCRIPTION OF ASSEMBLY

The tray is protected by a layer of **Tecbor®** 40 mm boards set together with 5.2x80 mm self-tapping screws. At duct section joints, place a 200 mm wide board strip of 20 mm **Tecbor®** and fix it to the metal tray and to each other using 3.5x45 mm screws.

The duct is anchored to the slabs with a 12 mm rod and supported by 50x50x5 mm angle sections.

Board joints and screw heads should be covered with **Tecbor®** joint paste ready to use.

Penetrations seals:

Fill the hole between the duct and the structural work with 50 mm and 145 kg/m³ rock wool and paint both sides with **Tecbor®** joint paste ready to use.



4. VENTILATION AND SMOKE EXTRACTION DUCTS

2 hours fire resistant, self-bearing, horizontal and vertical configuration

Tested under UNE EN 1366-1 standard. Fire resistance tests in service facilities. Part 1. Ducts. Classification according to UNE EN 13501-3: EI-120 (ve, ho i↔o) S (Type A and B horizontal and vertical configuration).

Tested under UNE EN 1366-8 standard. Fire resistance tests in service facilities. Part 18. Smoke extraction ducts (multi compartment) classification according to UNE EN 13501-4: EI-120 S 1500 (Type C).

The regulatory requirements demand the compartment of elements when traversed by installations, such as pipes or extraction and ventilation ducts.

The Technical Building Code states in its Basic Document in Case of a Fire SI 1, Interior Propagation, Section 3, Point 3:

Fire resistance required to the fire compartment elements must be kept on the points where such elements are traversed by installation materials, such as cables, pipes, ducts, ventilation ducts, etc. To that end, a choice can be made between the following alternatives:

a) Put an element which, in case of a fire, automatically blocks the cross section and guarantees in such point a fire resistance at least equal to that of the traversed element, for example, an automatic firewall damper. The $t(i↔o)$ being the fire resistance time required to the traversed compartment element, or a blocking intumescent device.

b) Crossing elements which provide a resistance at least equal to that of the traversed element, for example, EI ventilation ducts $t(i↔o)$ being t the fire resistance time required to the traversed compartment element.

From the previous paragraph follows that the fire resistant ducts which pass through fire compartments must have the compartments from within and from the outside to it.

RSCIEI describes in its annex II Article 5.7:

“Systems including ducts, both verticals and horizontal, which traverse compartment elements and whose function doesn't allow the use of dampers (smoke exhaust, ventilation of evacuation routes, etc.), must be fire resistant or adequately protected throughout its route with the same level of fire resistance than the traversed elements, and tested according to the applicable UNE-EN standards”.

UNE EN applicable standards, as they appear in Annex DB SI G of the TBC are:

- UNE EN 1366 Part 1 for ventilation ducts.
- UNE EN 1366 Part 8 for multi-sector extraction ducts.

4.1 VENTILATION DUCT TYPE A, B AND C. TECBOR® 30 EI-120

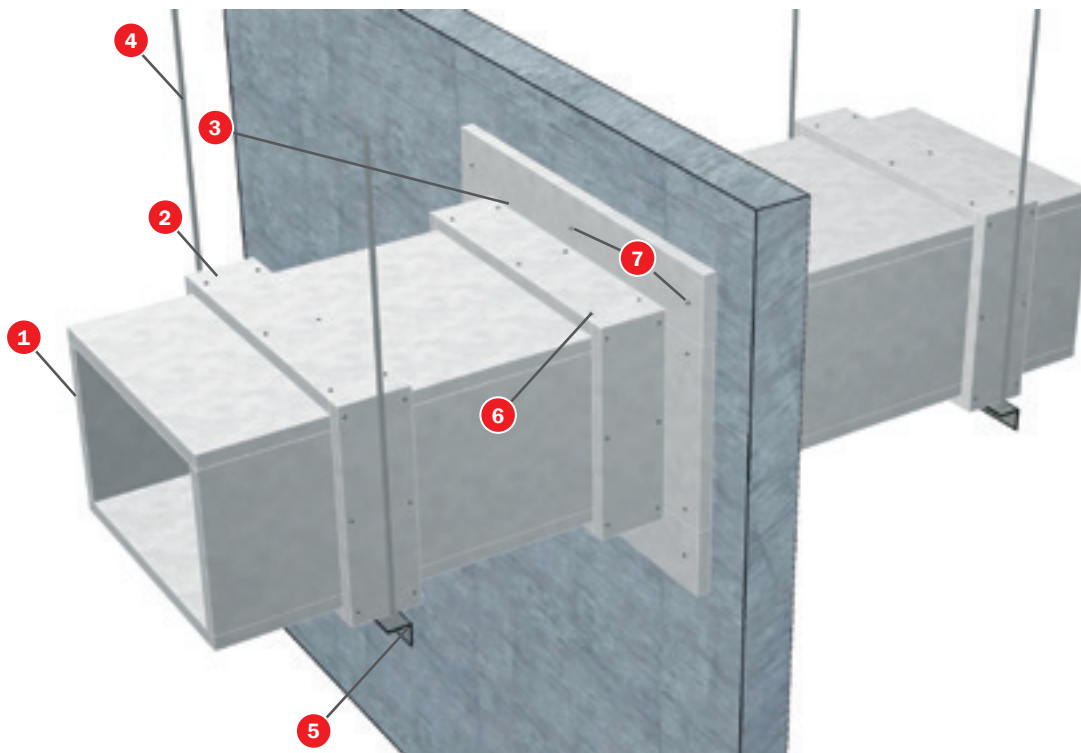

TEST

Standard: UNE EN 1366-1 and UNE EN 1366-8

Laboratory: TECNALIA y APPLUS.

Test N°: 14_07739, 15_08681, 14_07738, 14/8785-1293 and 14/8785-1237.

SOLUTION

- 1 Tecbor® 30 mm boards
- 2 Tecbor® 30 mm plate to cover joints
- 3 Tecbor® 30 mm perimeter ring
- 4 Threaded rod
- 5 50x50x5 mm L-shaped
- 6 5x60 mm threaded wood screws
- 7 6x80 mm metal anchors
- 8 Rock wool 50 mm thick and 145 Kg/m³
- 9 Tecsel® adhesive

DESCRIPTION OF ASSEMBLY

Duct composition:

Duct consisting of Tecbor® boards 30 mm thick.

Fixings between sections:

Longitudinally, the boards are joined with Tecsel® adhesive.

Transversally, duct sections are joined with perimeter joint covers formed by Tecbor® boards of 30 mm thick and 250 mm wide.

The joint covers are fixed to the section with 2 lines of 5 x 60 mm threaded wood screws, screwed every 250 mm on the long sides and 200 mm on the short ones. Lines distanced between each other 160 mm.

Duct support method:

The duct is supported by an auxiliary structure made up of M16 threaded rods and 50 mm x 50 mm and 5 mm thick L-shaped upon which the duct rests. Maximum distance between the hangs will be 1200 mm.

Sealing of the penetration point through the support work. Sealing will be carried out with the following elements:

- Tecbor® boards 30 mm thick.
- Rock wool 50 mm thick and density 145 Kg/m³

TECBOR®



Ventilation ducts

CONSTRUCTIVE SOLUTIONS FOR VENTILATION DUCTS*

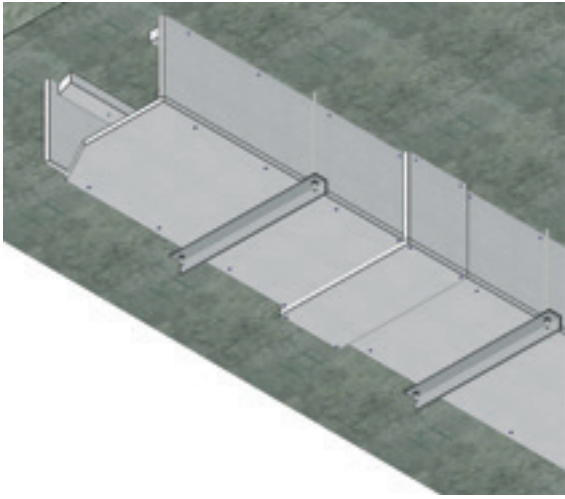

1. Horizontal duct 3 faces

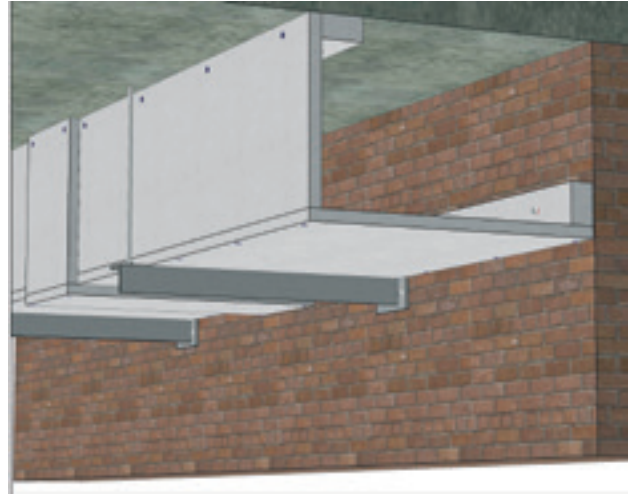

2. Horizontal duct 2 faces

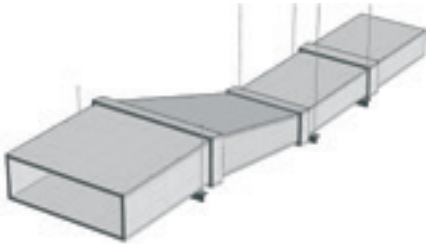

3. Section changes



4. Unevenness

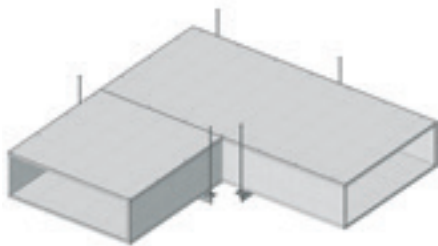

5. L-shape

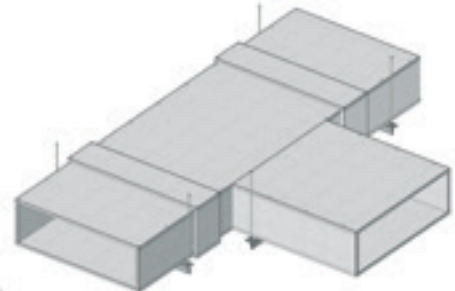

6. Branches

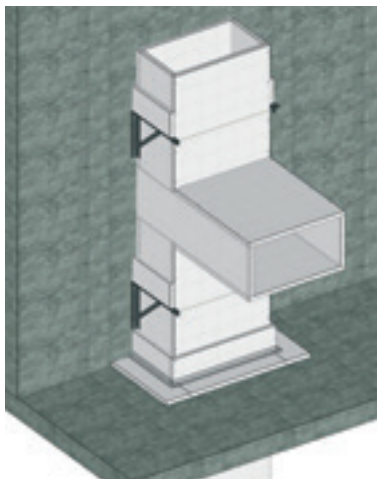

7. Vertical anchorage and horizontal splicing

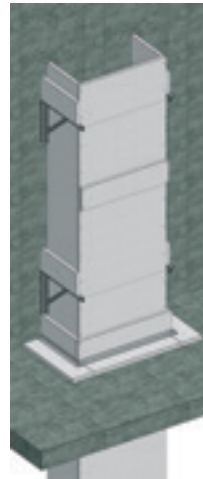

8. Vertical duct 3 faces



9. Vertical duct 2 faces

* Please, contact the commercial department for constructive details of conexions

5. NON-STRUCTURAL ELEMENTS. WALLS.

Non-structural walls, which separate fire areas, should be fire resistant as stipulated in standard EN 1364-1.

When in fire resistance tests for non-structural elements one edge is left free (Part 1: Walls), the standard allows increasing the width.

With regard to increasing the height, the standard is clear and precise. When the test is run at least at 3 metres high, it may be increased up to 4 metres.

Very often, internal partitions are higher than 4 metres. **Mercor tecresa**® have been the first to develop large partitions and offers the most efficient and convenient solution for this type of works.

Besides, penetrations produced between different fire sectors must be sealed off; for example, in the case of services crossing. Check the **TECSEL**® **Sealing System** catalogue to find the most suitable solution.

5.1 TECBOR® 12 WITHOUT WOOL - EI-60

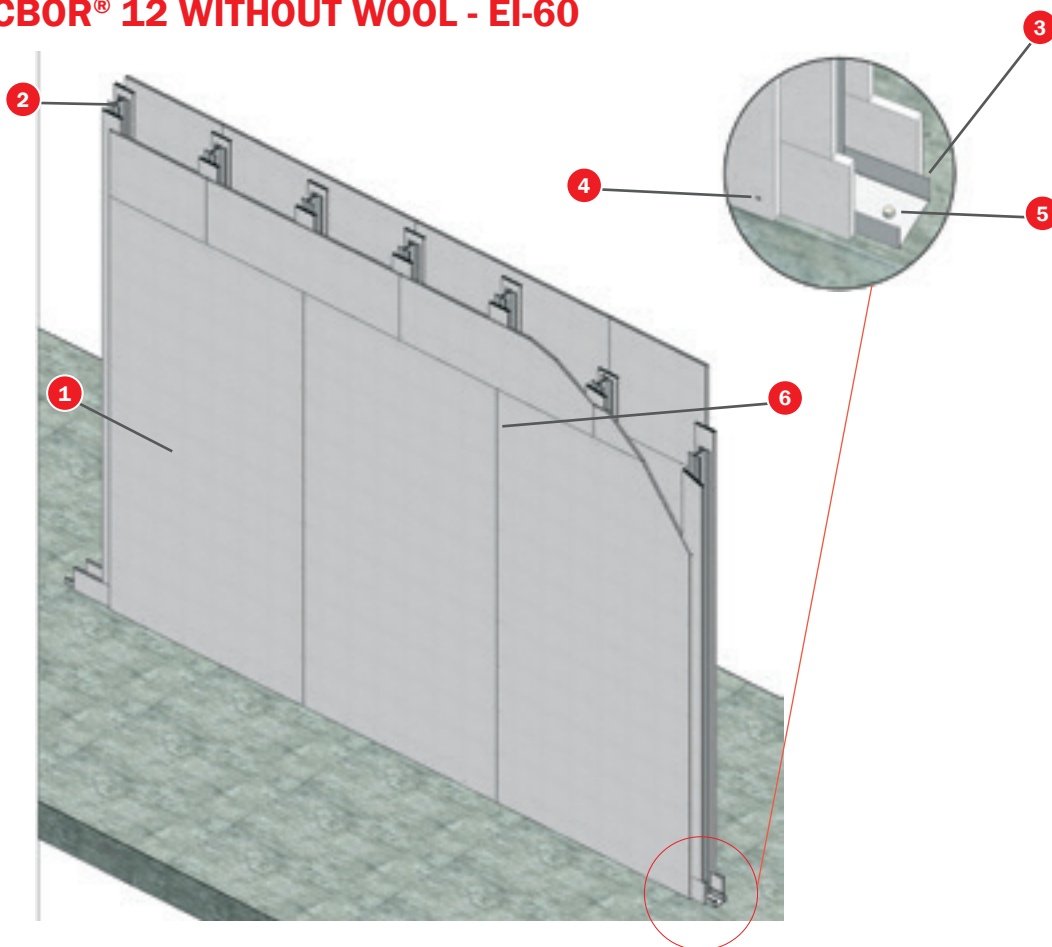

TEST

Standard: UNE EN 1364-1

Laboratory: TECNALIA

Test N°: 051497-1

SOLUTION

- 1 Tecbor® 12 mm boards
- 2 70x36x0,6 mm double metal stud H-shaped
- 3 73x30x0,5 mm metal runner
- 4 3,5x35 mm self-tapping screw
- 5 M6 metal plug
- 6 Tecbor® joint paste

DESCRIPTION OF ASSEMBLY

Fix 73x30x0.5 mm runners with M6 metal plug every 250-300 mm. Finish off the metal structure with 70x36x0.6 mm double studs arranged in "H" position with a 610 mm inter-axial distance.

Then fix Tecbor® 12 mm boards to both sides with 3.5x35 mm self-tapping screws every 200-250 mm.

Finally, cover board joints and screw heads with Tecbor® joint paste.

The metal studs shall be covered with some Tecbor® board strips, on which the boards will be screwed on.

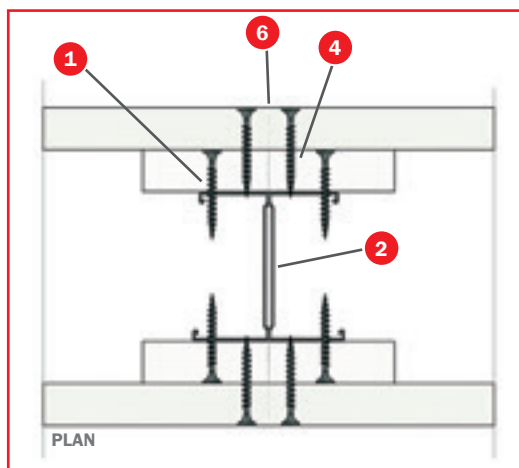

TECBOR®



Non-structural elements. Walls

5.2 TECBOR® EI-120 WALL

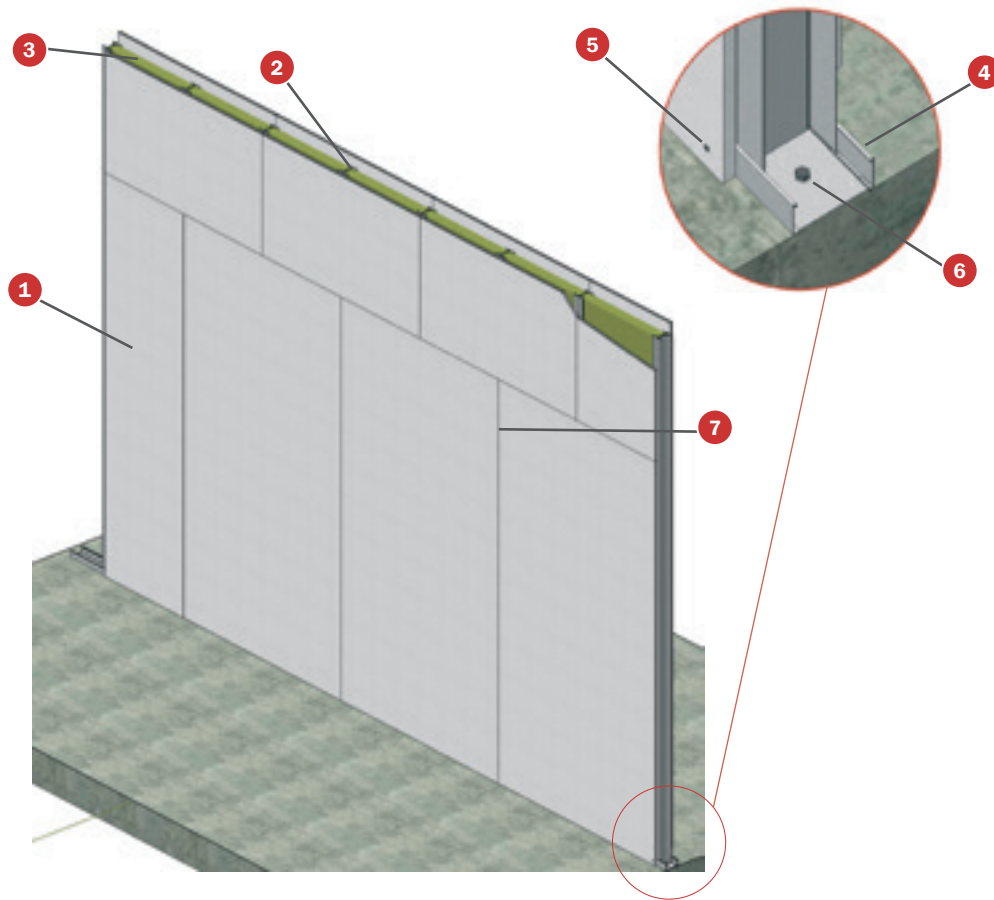

TEST

Standard: UNE EN 1364-1
Laboratory: TECNALIA
Test N°: 072951-005-1/2

SOLUTION

- 1 Tecbor® 12 mm boards.
- 2 70x36x0,6 mm double metal stud H-shaped.
- 3 80 mm (40+40) and 40 Kg/m³ density rock wool.
- 4 73x30x0,5 mm metal runner.
- 5 3,5x35 mm self-tapping screw (every 250 mm).
- 6 6 mm punch-activated drop-in anchor (every 600 mm).
- 7 Tecbor® joint paste or Tecbor® Bonding Compound.

DESCRIPTION OF ASSEMBLY

Fix 73x30x0,5 mm runners with M6 metal plug every 250-300 mm. Finish off the metal structure with 70x36x0,6 mm double studs arranged in "H" position with a 610 mm inter-axial distance.

Place rock wool panels between studs. Then fix Tecbor® 12 mm boards to both sides with 3.5x35 mm self-tapping screws every 200-250 mm.

Finally, cover board joints and screw heads with Tecbor® joint paste or Tecbor® Bonding Compound.

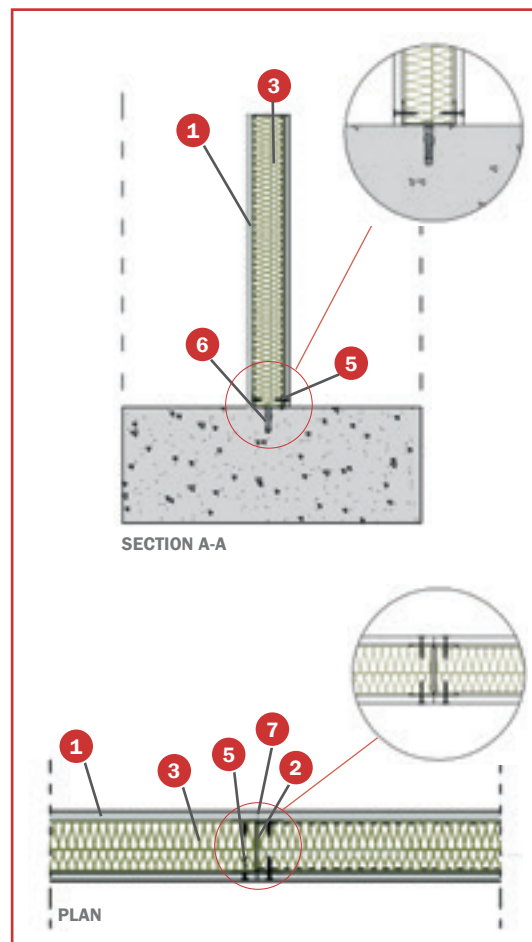

5.3 TECBOR® EI-180 WALL

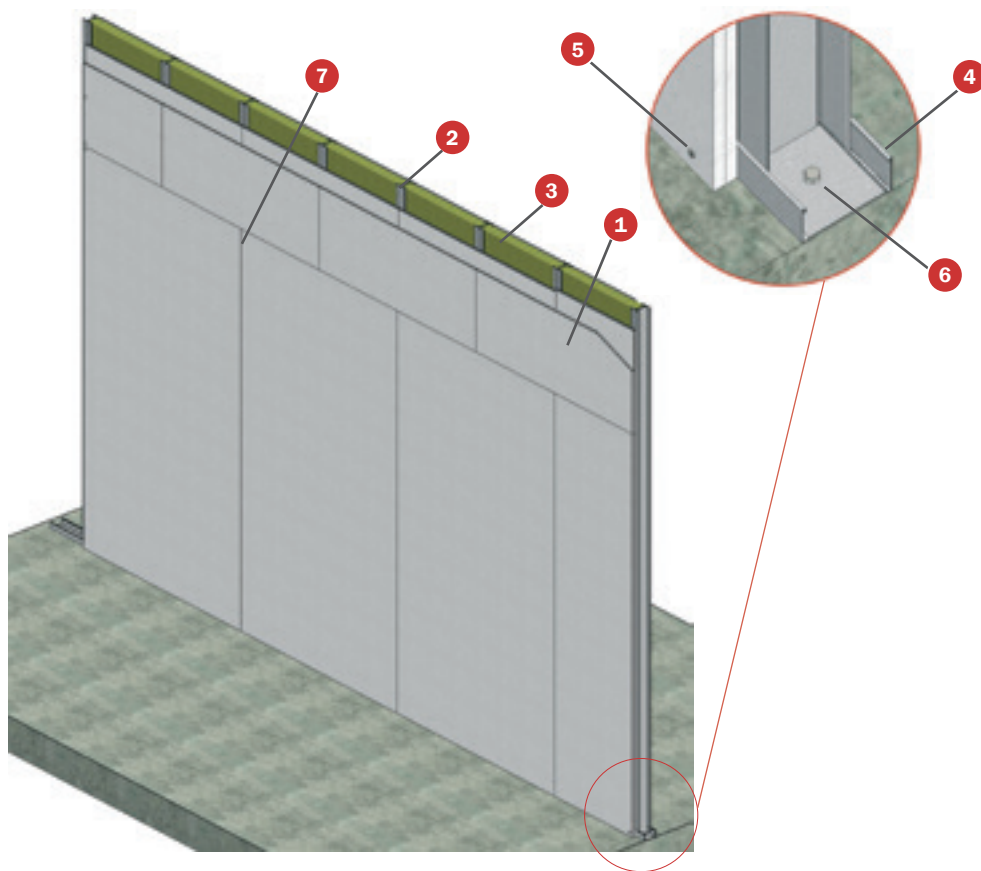

TEST

Standard: UNE EN 1364-1

Laboratory: TECNALIA

Test N°: 072951-006-1/2

SOLUTION

- 1 Tecbor® 10 mm boards.
- 2 70x36x0,6 mm double stud H-shaped.
- 3 80 mm (40+40) and 40 Kg/m³ density rock wool.
- 4 73x30x0,5 mm metal runner.
- 5 3,5x35 mm self-tapping screw.
- 6 M6 metal plug.
- 7 Tecbor® joint paste or Tecbor® Bonding Compound.

DESCRIPTION OF ASSEMBLY

Fix 73x30x0.5 mm runners with M6 metal plug every 250-300 mm. Finish off the metal structure with 70x36x0.5 mm double studs arranged in "H" position with a 610 mm inter-axial distance.

Place rock wool panels between studs. Then fix the two layers of Tecbor® 10 mm boards to both sides with 3.5x35 mm selftapping screws every 200-250 mm, overlapping boards of each layer.

Finally, cover board joints and screw heads with Tecbor® joint paste or Tecbor® Bonding Compound.

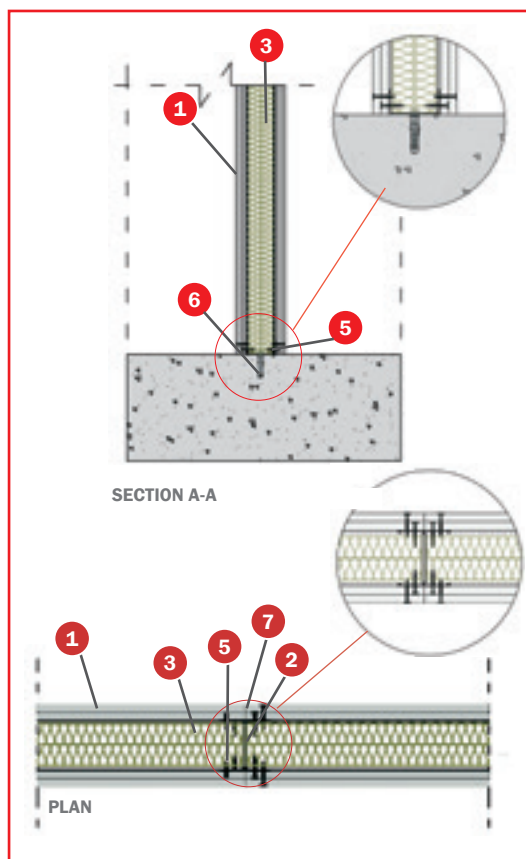

TECBOR®



Non-structural elements. Walls.

5.4 TECBOR® EI-240 WALL

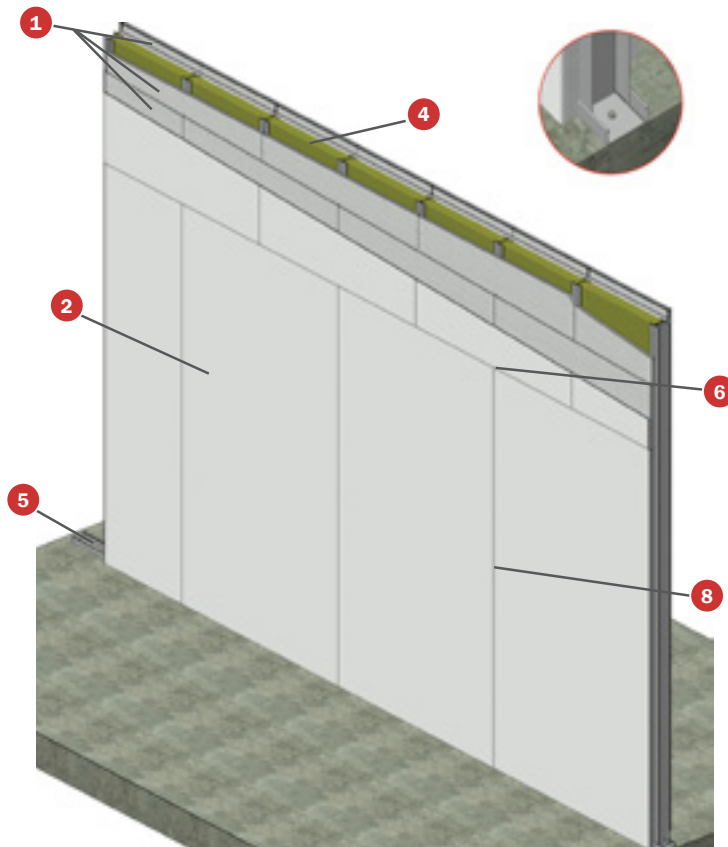

TEST

Standard: UNE EN 1364-1
Laboratory: TECNALIA
Test N°: 076765-001/2

SOLUTION

- 1 Tecbor® 15 mm boards.
- 2 12,5 m laminated plasterboard.
- 3 46x0,6 mm H-shaped double stud.
- 4 80 mm and 40 kg/m³ rock wool.
- 5 48x0,6 mm runner.
- 6 3,5x35,45 and 55 mm self-drilling screw (every 250 mm).
- 7 Punch-activated drop-in 6 mm anchor, every 600 mm.
- 8 Tecbor® Bonding Compound (on every joint and over the screw heads)

DESCRIPTION OF ASSEMBLY

Fix 48x0,6 mm runners and assembly the 46x0,6 mm studs every 600 mm. Place 80 mm (40+40) and 40 Kg/m³ rock wool panels between studs.

Then fix Tecbor®15 mm boards to both sides with 3.5x35 mm self-tapping screws every 250 mm.

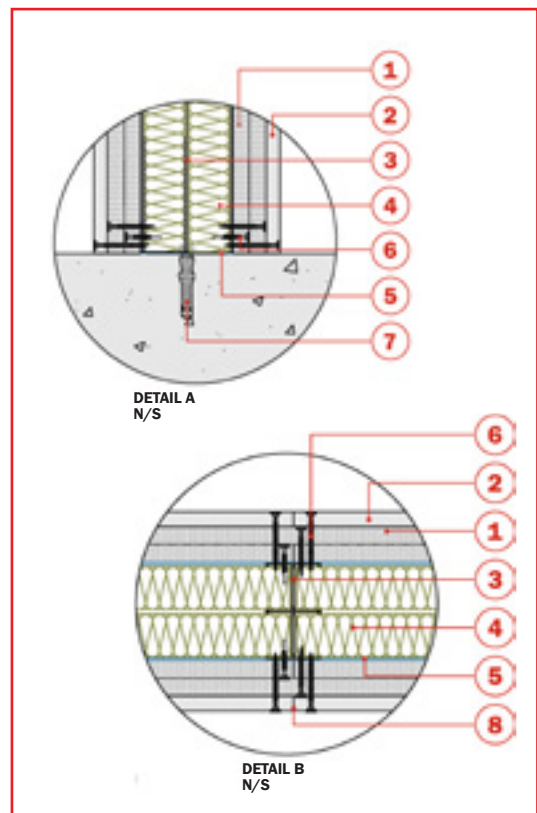

Finally, cover board joints and screw heads with Tecbor® joint paste or Tecbor® Bonding Compound.



5.5 TECBOR® EI-120 INDEPENDENT WALL LINING

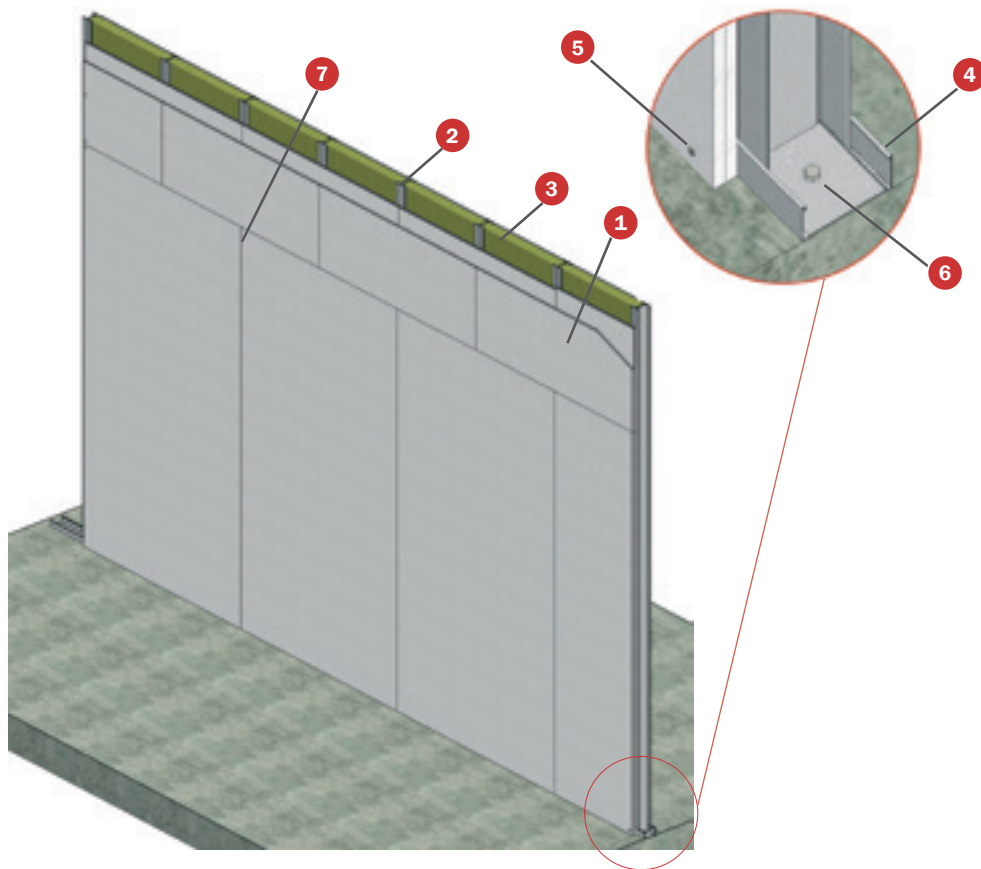

TEST

Standard: UNE EN 1364-1

Laboratory: TECNALIA

Test N°: 072951-008-1/2

SOLUTION

- 1 **Tecbor®** 12 mm boards.
- 2 70x36x0,6 mm H-shaped stud.
- 3 80 mm (40+40) and 40 Kg/m³ density rock wool.
- 4 73x30x0,5 mm metal runner.
- 5 3,5x35 mm self-tapping screw.
- 6 **Tecbor®** joint paste or **Tecbor® Bonding Compound**.
- 7 IPN 140 metal profile.
- 8 30x30x0,6 mm angle.
- 9 M6 metal plug.

DESCRIPTION OF ASSEMBLY

Fix 73x30x0.5 mm runners and assemble the 70x36x0,6 mm studs every 610 mm.

Place 80 mm rock wool panels between studs. Then fix the two layers of **Tecbor®** 12 mm boards to both sides with 3.5x35 mm self-tapping screws every 200-250 mm, overlapping boards of each layer.

Finally, cover board joints and screw heads with **Tecbor® joint paste** or **Tecbor® Bonding Compound**.

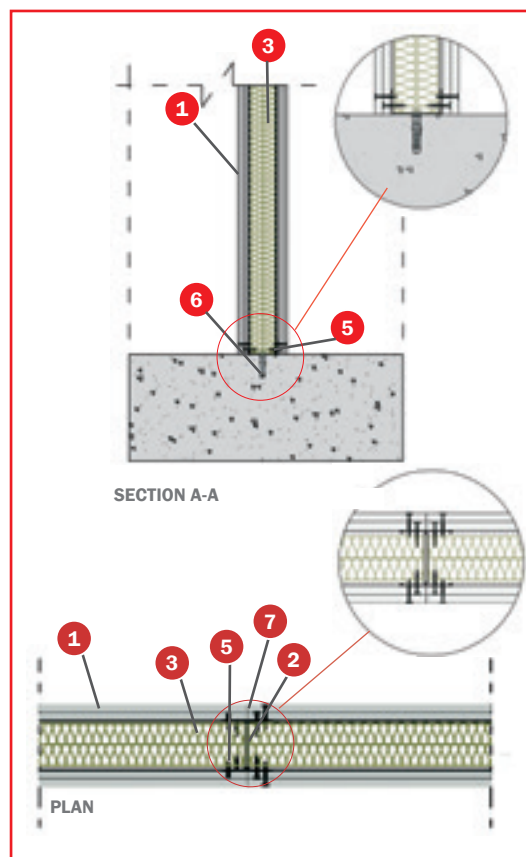

TECBOR®



Non-structural elements. Walls.

5.6 TECBOR® EI-120 2-SIDED FIRE INDEPENDENT WALL LINING

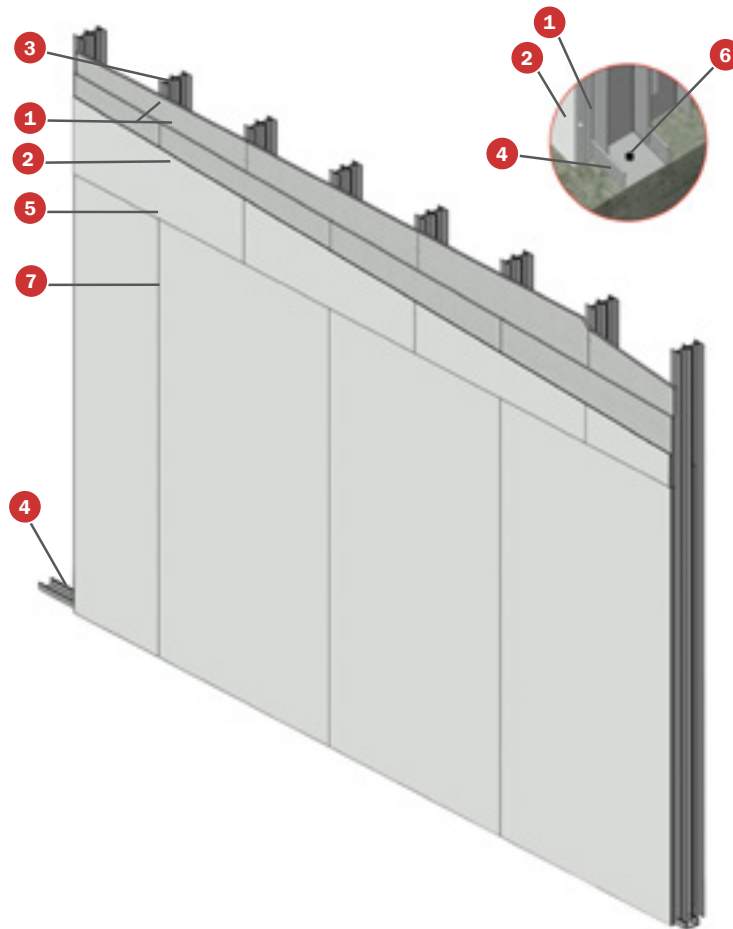

TEST

Standard: UNE EN 1364-1

Laboratory: TECNALIA

Test N°: 076765-002-1/2

SOLUTION

- 1 Tecbor® 15 mm boards.
- 2 12,5 m laminated plasterboard.
- 3 34,8x40x0,5 mm H-shaped double stud.
- 4 83x40x0,6 mm runner.
- 5 3,5x35,45 and 55 mm self-drilling screw (every 250 mm).
- 6 Punch-activated drop-in 6 mm anchor, every 600 mm.
- 7 Tecbor® Bonding Compound (on every joint and over the screw heads)

DESCRIPTION OF ASSEMBLY

Fix 83x40x0,6 mm runners and assembly the 34,8x40x0,6 mm studs every 600 mm.

then fix Tecbor® 15 mm boards to both sides with 3.5x35 mm self-tapping screws every 250 mm.

Finally, cover board joints and screw heads with Tecbor® joint paste or Tecbor® Bonding Compound.

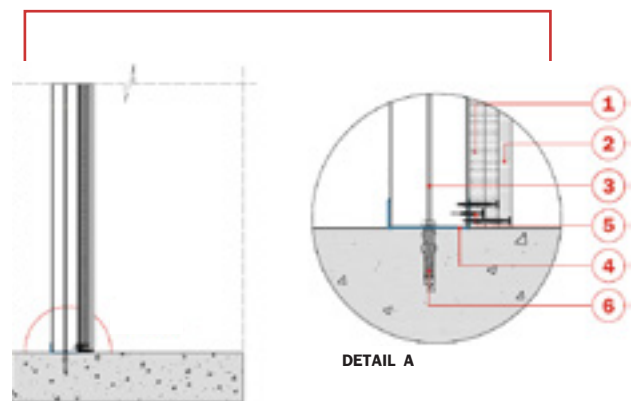

HORIZONTAL SECTION DETAIL
Scale 1/10

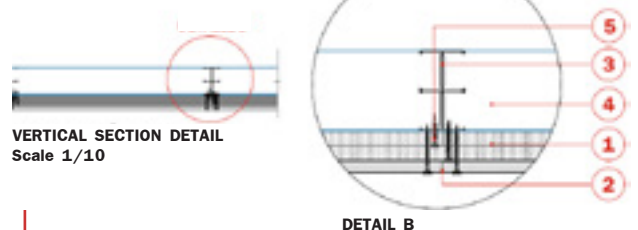

VERTICAL SECTION DETAIL
Scale 1/10



5.7 TECBOR® EI-180 INDEPENDENT WALL LINING

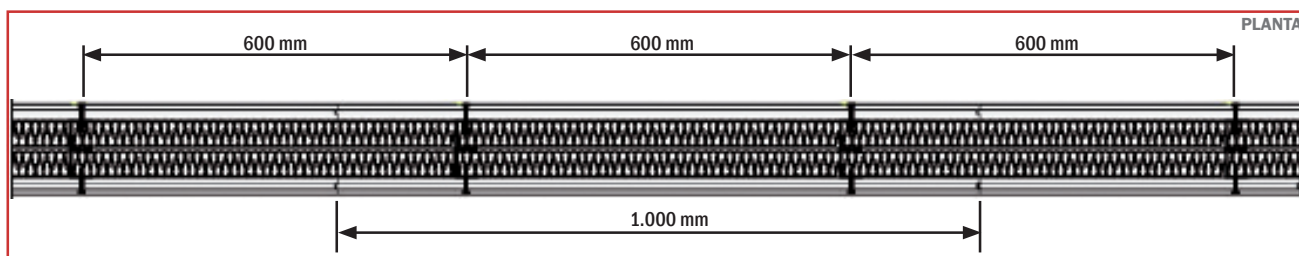
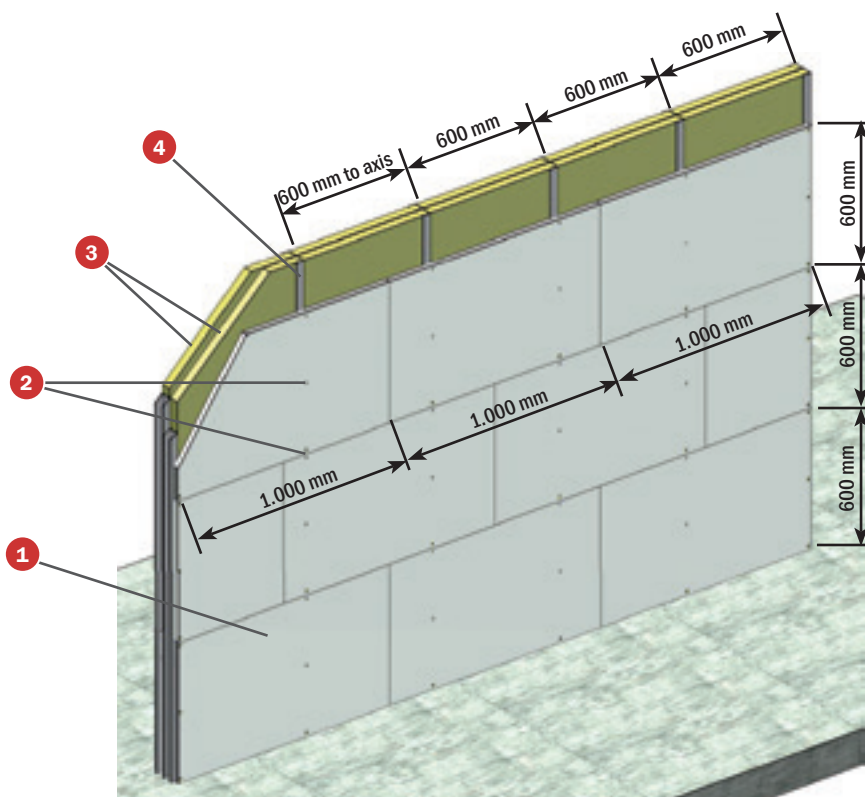

TEST

Standard: UNE EN 1366-1

Laboratory: TECNALIA

Test N°: 24237-3/4

SOLUTION

- 1 Tecbor® Y 25 mm Boards.
- 2 Self-tapping screw 3,5x35 mm.
- 3 Mineral wool 40 mm and 40 kg/m³.
- 4 Stud framing 46x36x0,6 mm.

DESCRIPTION OF ASSEMBLY

Fixing the 46x30x0,5 mm channels through M6 metallic dowel each 250-300 mm. Complete the double metallic structure with 46x36x0,5 mm stud framing separated 600 mm between axes.

Place the mineral wool boards between the stud framing.

Fix afterwards the two layers of Tecbor® Y 25 mm to both sides with 3,5x35 mm self-tapping screws each 200-250 mm.

Finally, cover the joints between boards and the screws head with Tecbor® joint paste.

TECBOR®



Non-structural elements. Walls.

METALWORK ASSEMBLY FOR LARGE PARTITIONS (> 4 M HIGH)

If partitions are above 4 m high, additional reinforcement must be provided.

This structural solution consists of 5 easy-to-install pieces protecting the partition against the stress caused by dilation and temperature variations, and the masonry seating itself.

mercor tecresa[®] has tested the metalwork assembly for partitions higher than 4 meters. Consult with our technical department for further information.



6. CURTAIN WALLS

The DBSI in its section concerning external propagation, indicates that in order to limitate the risk of vertical propagation through the façade between two fire sectors, between a particularly high risk area and other higher zones in the building, or towards a protected staircase or protected corridor, this façade shall be at least EI-60 in a belt with height of not less than 1 metre.

Catastrophes affecting high-rises have shown the importance of protecting and anchoring joints between both slabs and facades. Otherwise, existing holes between curtain walls and light facades can work as true chimneys in case of fire causing flames and smoke to get out of control propagating into higher areas in the building, and thus hampering an orderly evacuation procedure.

The manifold and various configurations of facades make it difficult to decide on the most appropriate protection. Therefore, do not hesitate to contact our Sales Department for assistance.

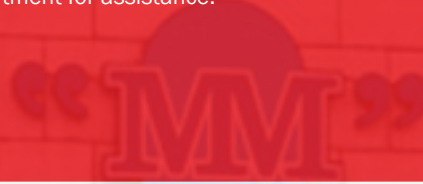

6.1 TECBOR® 20 - EI-60 INDEPENDENT CURTAIN WALL.

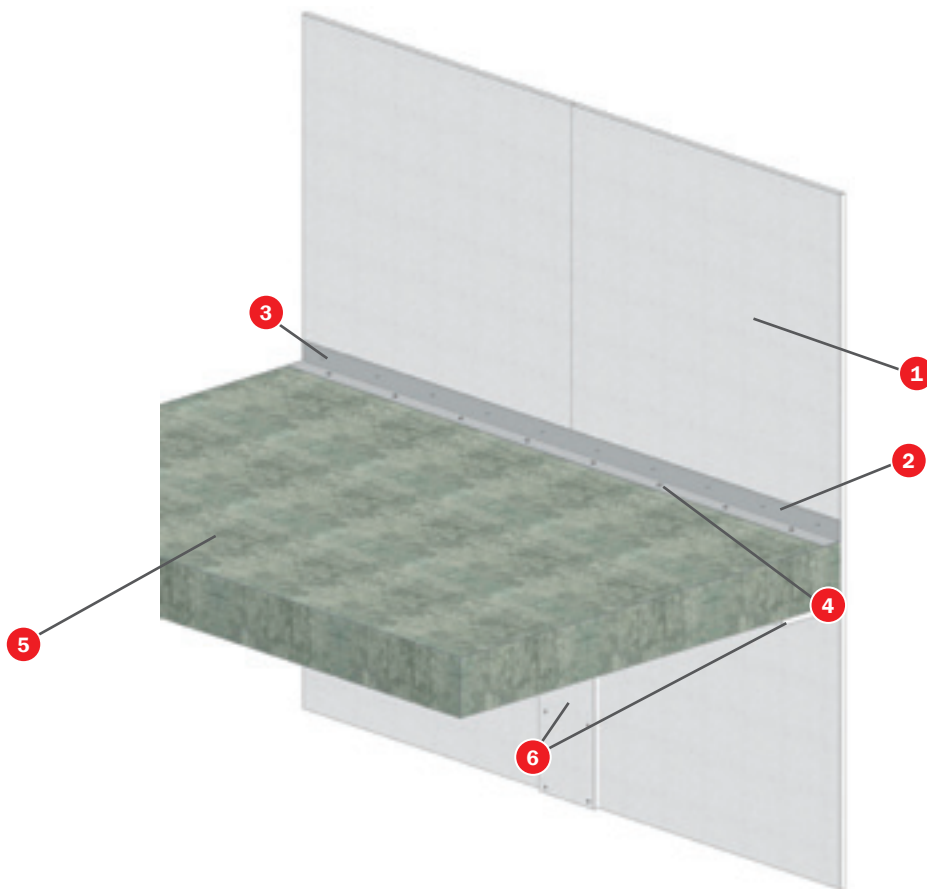

TEST

Standard: UNE EN 13501-2

Laboratory: CIDEMCO

Test N°: 22100-1/2-M1

SOLUTION

- 1 Tecbor® 20 mm boards
- 2 70x70x1 mm metal angle
- 3 3,5x45 mm self-tapping screw
- 4 10x100 mm metal plug
- 5 Slabs
- 6 Tecbor® 20 mm plate to cover joints

DESCRIPTION OF ASSEMBLY

Fix the 70x70x1 mm supporting angle lengthways to the Tecbor® B 20 mm board using 3.5x45mm self-tapping screws every 250- 300 mm approximately. Place the angle right next to the slab edge using a 10x100 mm plug every 250-300 mm approximately. Then place Tecbor® 20 mm plates 200-250 mm wide on the lower end of the slabs using a 10x100 plug. Tecbor® 20 mm plates 200 a 250 mm wide are fixed on top of the lower end of the curtain wall using 3.5x45 mm self-tapping screws.

Then Tecbor® joint paste is applied to all screw heads and between boards.

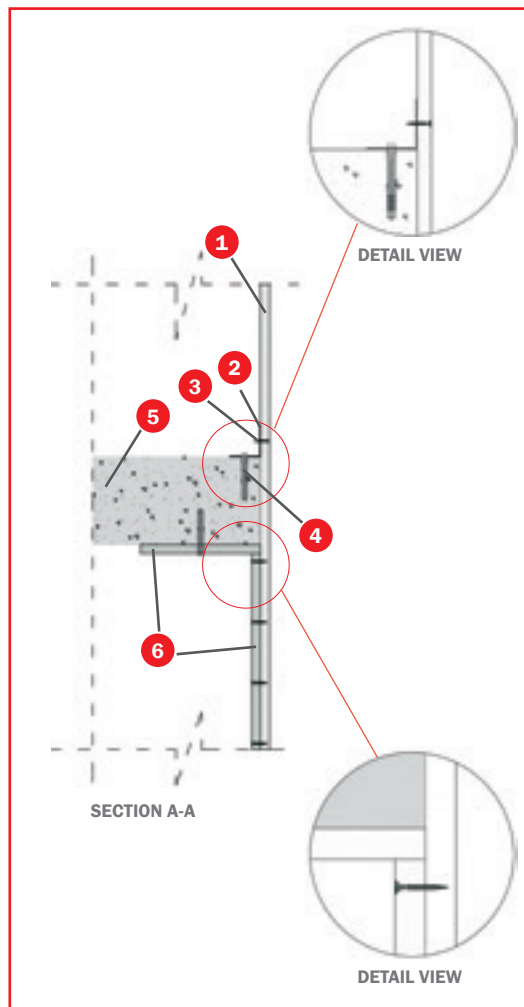

TECBOR®



Curtain walls

6.2 TECBOR® 20 - EI-90 CURTAIN WALL WITHOUT CROSSING SLAB

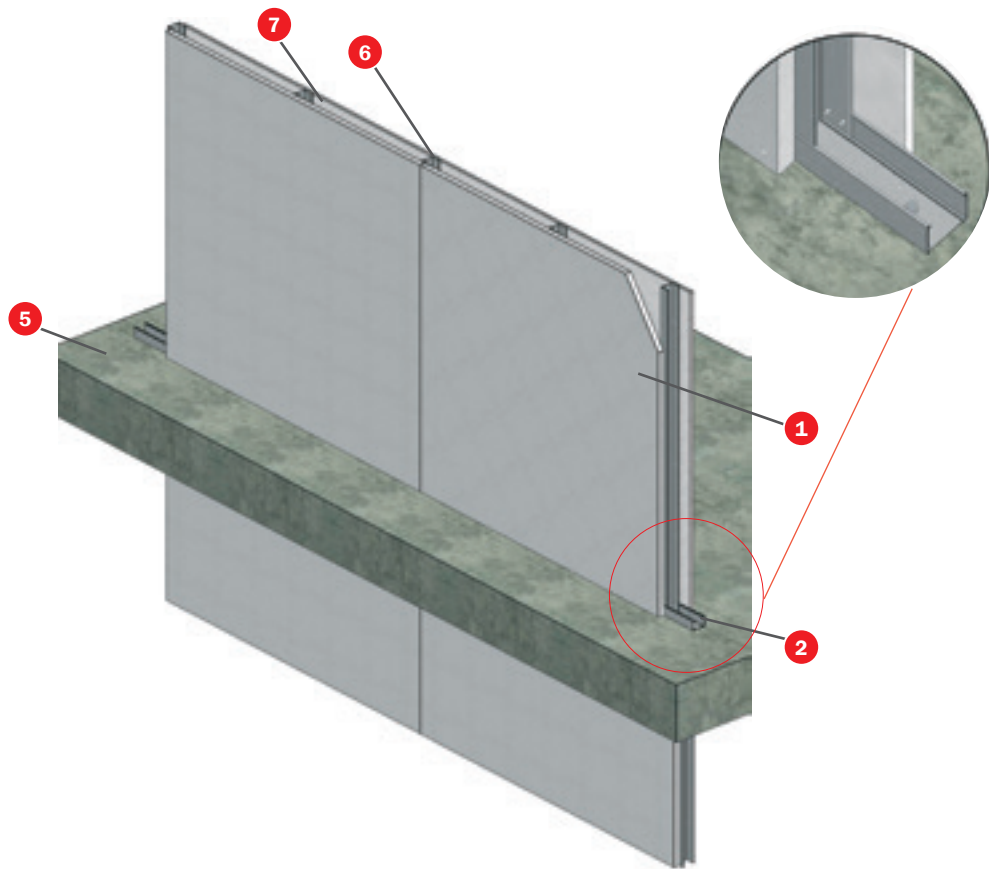

TEST

Standard: UNE EN 1364-1

Laboratory: CIDEMCO

Test N°: 18598-1/-2 M1

SOLUTION

- 1 Tecbor® 20 mm boards
- 2 48x30x0,5 mm metal runner
- 3 3,5x35 mm self-tapping screw
- 4 10x60 mm metal plug
- 5 Slabs
- 6 46x36x0,6 mm metal stud
- 7 13 mm plasterboard panel

DESCRIPTION OF ASSEMBLY

Attach a 48x30x0.5 mm metal runner to the slab using a 10x60 mm metal plug. Then place the 46x36x0.6 mm studs at a distance of 610 mm between axes. Fix the Tecbor® 20 mm boards to the structure with 3.5x35 mm screws.

Apply Tecbor® joint paste to screw heads and between boards.

Finally, a 13 mm plasterboard panel is fixed inside using 3.5x35 mm self-tapping screws.

Two configurations of this solution have been tested: upper and lower curtain wall to meet works requirements as appropriate.

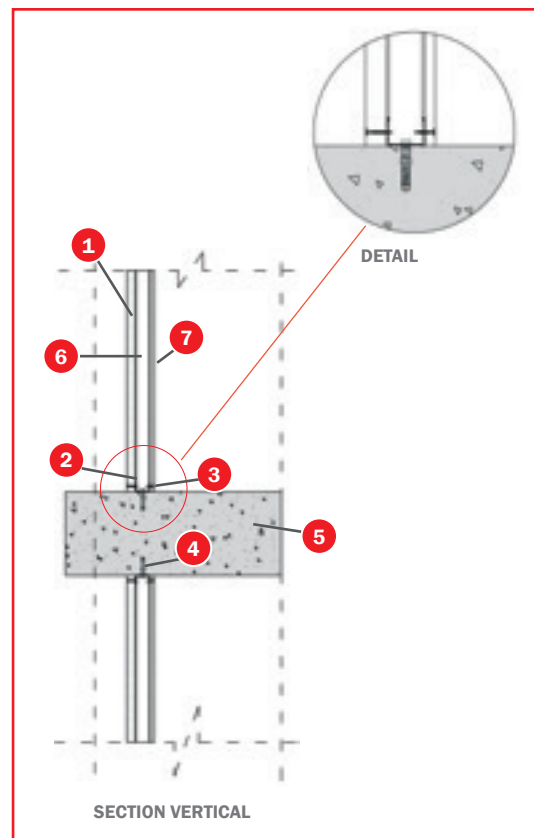

6.3 TECBOR® 20 - EI-120 CURTAIN WALL

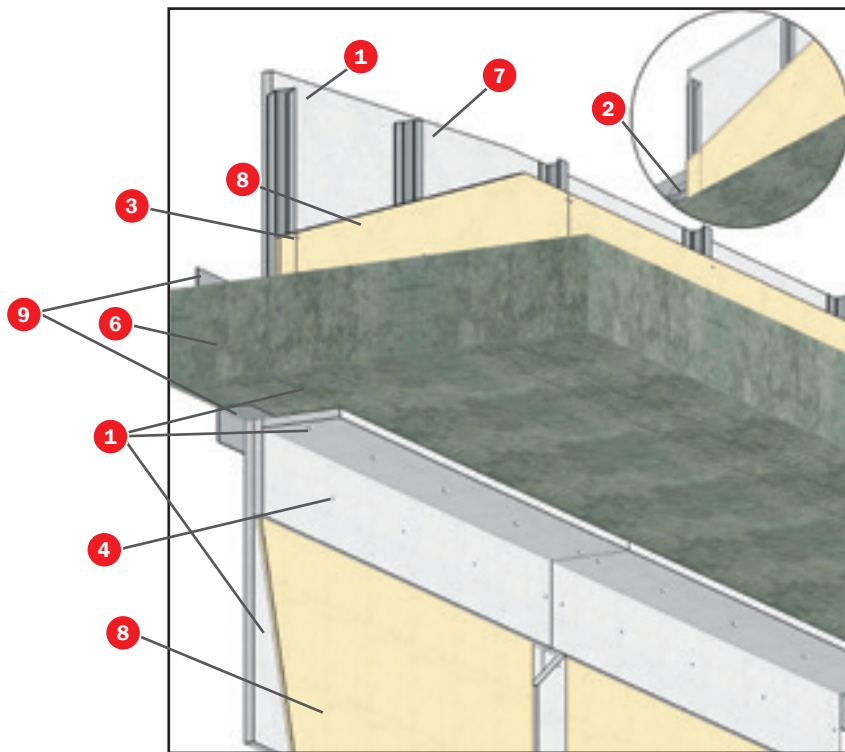

TEST

Standard: UNE EN 1364-1

Laboratory: CIDEMCO

Test N°: 12_02712

SOLUTION

- 1 Tecbor® 20 mm boards
- 2 48x30x0,5 mm metal runner
- 3 3,5x35 mm
- 4 3,5 x 45 mm self-tapping screw
- 5 10x60 mm metal plug
- 6 Slabs
- 7 46x36x0,6 mm metal stud
- 8 13 mm plasterboard panel
- 9 70 x 70 x 1 mm angle

DESCRIPTION OF ASSEMBLY

This is a curtain wall solution without assymetrical crossing slab. The upper side, is a partition without wool.

It consists in a 13 mm laminated plaster partition fixed on the inner side to a 46 mm metal stud by means of 3.5 x 35 mm dry partition hardware. On the opposite side, it has a 20 mm **Tecbor®** board fixed to the 46 metal stud by means of 3.5 x 35 mm dry partition hardware.

On the slab lower part, **Tecbor®** boards were installed with 70 x 70 x 1 mm angle and 3.5 x 45 mm screw.

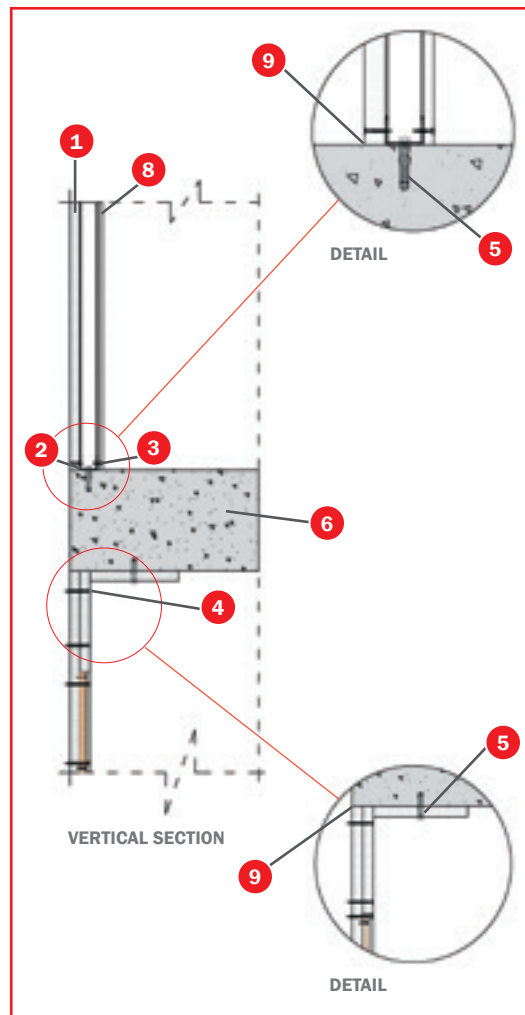

TECBOR®



Curtain walls

6.4 TECBOR® 30 CURTAIN WALL WITHOUT CROSSING SYSTEM EI-60

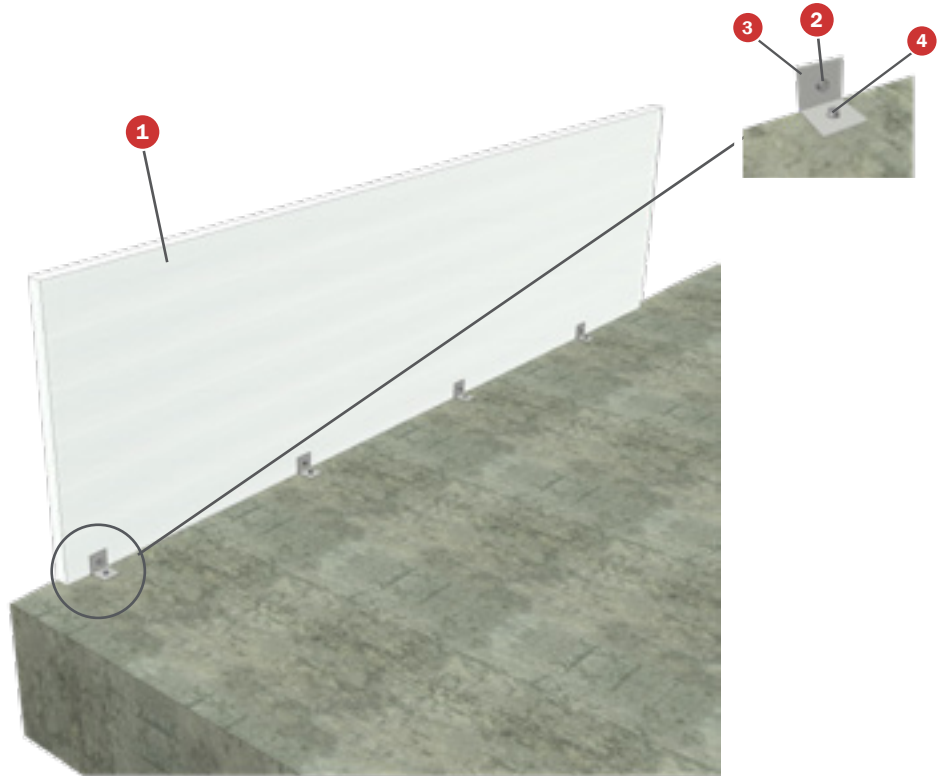

TEST

Standard: UNE EN 1364-4

Laboratory: TECNALIA

Test N°: 074490-001-1/2

SOLUTION

- 1 Tecbor® 30 mm Boards
- 2 Fixing angle
- 3 40.40.2 mm metal angle
- 4 M6 metal plug
- 5 3,5x45 mm screw
- 6 70.70 mm metal stud

DESCRIPTION OF ASSEMBLY

Fix the 40x40x2 mm supporting metal angle to the **Tecbor®** 30 mm board using fixing anchors every 500 mm.

Once the angles are fixed to the boards, fix to the slab using M6 metal plugs. Then place **Tecbor®** 30 mm plates 250 mm wide using 3.5x45 mm screws.

Then **Tecbor® Joint Paste** or **Tecbor® Bonding Compound** is applied to all screw heads and between boards.

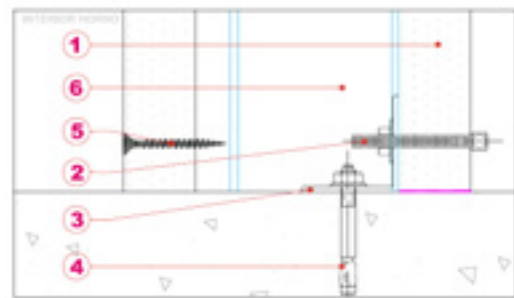

DETAIL A
NO SCALE

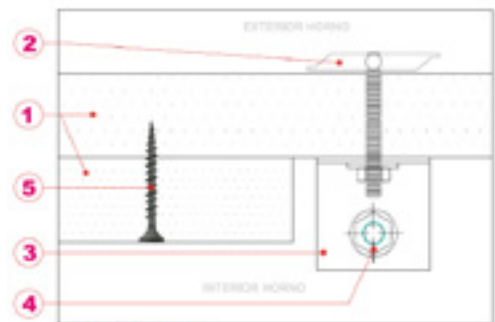

DETAIL A
NO SCALE



7. TUNNELS

In the last years, due to fire events occurred in tunnels, efficient solutions have been sought to safeguard their structural integrity.

The purpose of **mercortecresa**[®] is to guarantee people's safety by ensuring tunnel stability and integrity, ultimately increasing the time needed for evacuation.

Currently the EU has established within its territory the European Directive 2004/54/EC; including Spain by Royal Decree 635/2006 for tunnels, although they technically lack of established regulations. Technicians must base on the procedures acquired in other countries, such as the NFP 502, the Dutch RWS or German ZTV among others. This last one internationally recognized.

Mercortecresa[®] offers solutions for tunnel protection based on the Dutch RWS, in which heating curve is described a higher temperature peak. This makes our solutions to cover the most unfavorable conditions during a fire.

Furthermore **mercortecresa**[®], has conducted tests in a real tunnel, adding fire power (combustible diesel) with an approximate power output of 15 Mw. These tests were conducted on the Siero tunnel (TST).



TURA
BY -



7.1 TECBOR® 20+20 - REI-60 CONCRETE PROTECTION INSIDE TUNNEL.



TEST

Laboratory: Tunnel Safety Testing S.A. (TST)

Test N°: TEST real.

SOLUTION

- 1 Tecbor® 20 mm boards
- 2 15x45x0,5 mm Omega
- 3 Slab
- 4 3,5x45 mm self-tapping screws
- 5 4,2x55 mm self-tapping screws
- 6 8x46 mm metal anchors
- 7 8x76 mm metal anchors
- 8 Tecbor® joint paste

DESCRIPTION OF ASSEMBLY

The ceiling is protected with 2 Tecbor® 20 mm boards. First, attach 15x45x0.5 mm omega metal profiles every 610 mm, directly to concrete slab using an 8x46 mm metal anchor. Then fix the first Tecbor® 20 mm board with the 3.5x45 mm self-tapping screws. The second Tecbor® 20 mm board is fixed with 4.2x55 mm self-tapping screws.

Walls are protected using Tecbor® 20 mm boards anchored directly to the concrete. To fix the first

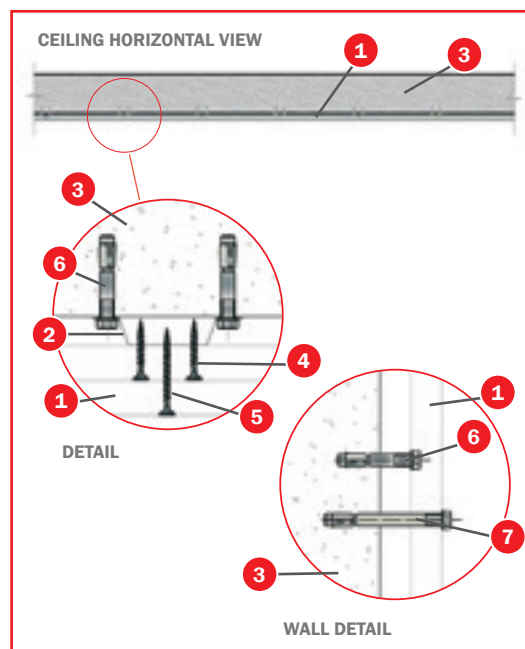

board, use 8x46 mm metal anchors. For the second board, use 8x76 mm metal anchors M6.

Apply Tecbor® joint paste to joints between boards, both in the ceiling and the walls.

Contact our technical department for further information.



7.2 TECBOR® 20 - REI-120 TUNNEL SUSPENDED CEILING



48

TECBOR®



Tunnels

TEST

Standard: UNE EN 1364-2. Standard Hydrocarbon Heating Curve

Laboratory: CIDEMCO

Test N°: 17566-1/-2-a-M1

SOLUTION

- 1 Tecbor® 20 mm boards
- 2 120 mm thick slab
- 3 10x60 mm metal plug
- 4 Tecbor® joint paste

DESCRIPTION OF ASSEMBLY

Fix **Tecbor®** 20 mm board directly to concrete slab using a 10x60 mm metal plug.

Apply **Tecbor® joint paste** to joints between boards, both in the ceiling and the walls.

Contact our technical department for further information.

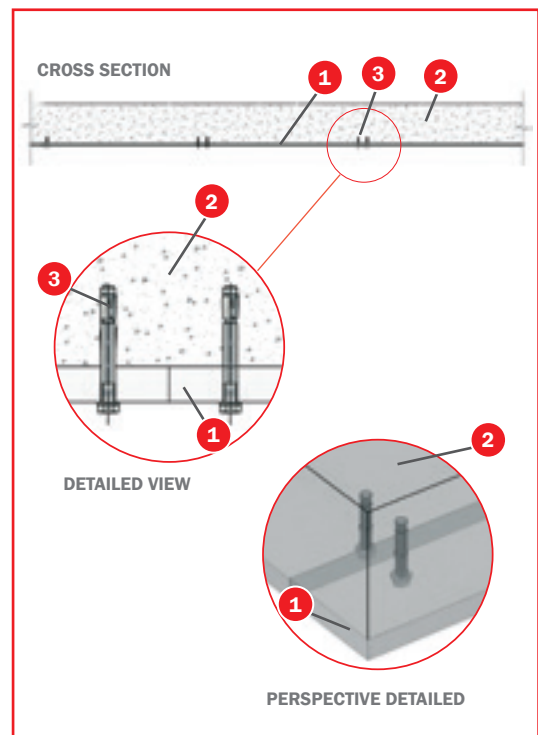

7.3 TECBOR® 40 TUNNEL SUSPENDED CEILING ON METAL STRUCTURE. RWS-120 AND RWS-180



EI-120

TEST

Standard: RWS Fire Curve
Laboratory: EFACTIS
Test N°: 2009-Efectis-R0998

SOLUTION

- 1 Tecbor® 40 mm boards
- 2 Slabs
- 3 Concrete wall
- 4 Metal profiles

EI-180

TEST

Standard: RWS Fire Curve
Laboratory: EFACTIS
Test N°: 2009-Efectis-R0999

SOLUTION

- 1 Tecbor® 40 mm boards
- 2 Slabs
- 3 Concrete wall
- 4 Metal profiles



SOLUTION 1

- 1 Tecbor® 40 mm boards
- 2 Expanding metal anchor with inner thread
- 3 Steel threaded rod Ø 12 mm
- 4 Zinc coated nut Ø 12 mm
- 5 75x46x1,2 mm metal profile
- 6 75x40x1,2 mm metal profile
- 7 5,5x73 mm screw
- 8 Plug anchoring + 10x100 mm screw
- 9 Tecsel® mastic for joints
- 10 Reinforced concrete slab

DESCRIPTION OF ASSEMBLY

Install the metal structure that will support the suspended ceiling forming a grid (refer to Technical Department for sizes) with primary profiles and secondary profiles sized 75x46x1.2 mm and 75x40x1.2 mm respectively.

Once the metal structure is in place, fix the **Tecbor®** 40 mm board to it using 5.5x73 mm self-drilling screws.

Mercor tecsasa® offers different assembly options. Please contact the Technical Department.

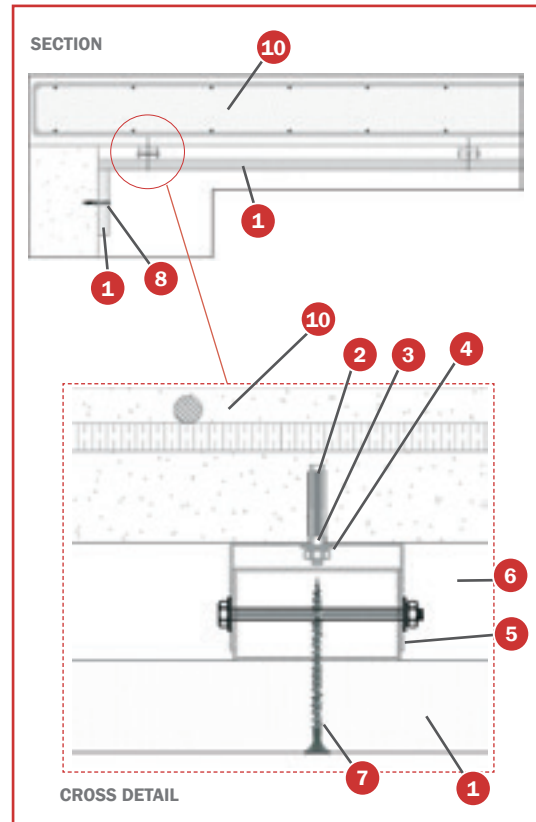

SOLUTION 2

- 1 Tecbor® 40 mm boards for tunnel
- 2 Expanding metal anchor with inner thread
- 3 Steel threaded rod Ø 12 mm
- 4 Zinc coated nut Ø 12 mm
- 5 75x46x1,2 mm metal profile
- 6 Tecbor® 12 mm boards
- 7 6,3x65 mm screw
- 8 4,5x50 mm Hi-Low screw
- 9 Tecsel® mastic for joints
- 10 Reinforced concrete slab

DESCRIPTION OF ASSEMBLY

Install the metal structure that will support the suspended ceiling forming a grid (refer to Technical Department for sizes) using primary profiles 75x46x1.2 mm in size. The secondary profile is replaced with a strip of **Tecbor®** 12 mm board 150 mm wide.

Once the metal structure is in place, fix the **Tecbor®** 40 mm board to it using 6.3x65 mm self-drilling screws.

Mercor tecsasa® offers different assembly options. Please contact the Technical Department.

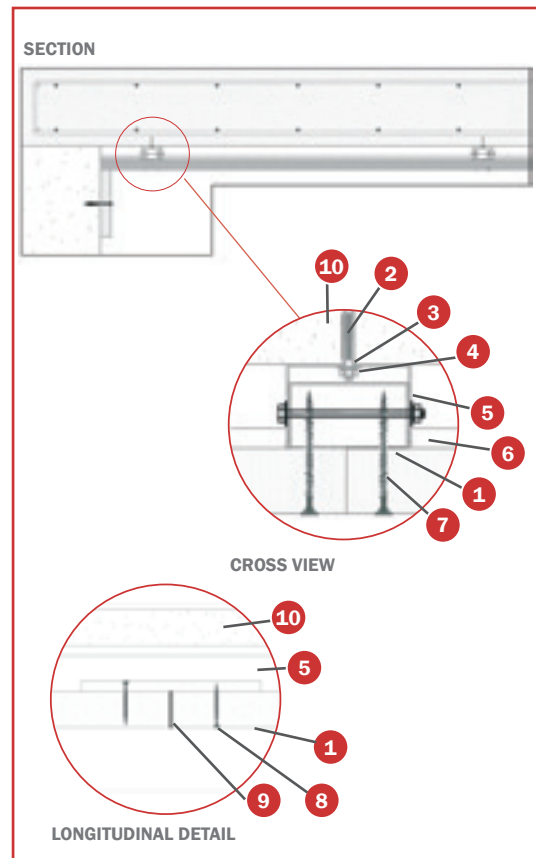

SOLUTION 3

- 1 **Tecbor**[®] 40 mm boards
- 2 Expanding metal anchor with inner thread \varnothing 12 mm
- 3 Steel threaded rod \varnothing 12 mm
- 4 Zinc coated \varnothing 12 mm
- 5 Pivot TC-60 Steel grip, e= 0,6 mm
- 6 TC-60 connection
- 7 5x80 mm screw
- 8 Plug anchoring + 10x100 mm screw
- 9 **Tecsel**[®] mastic for joints
- 10 Concrete slab
- 11 TC 60/27 profile

DESCRIPTION OF ASSEMBLY

Install the metal structure that will support the suspended ceiling forming a grid (refer to Technical Department for sizes) with a TC 60/27 profile. Once the metal structure is in place, fix the **Tecbor**[®] 40 mm board to it using 5.5x73 mm self-drilling screws.

Mercor tecresa[®], offers different assembly options. Please contact the Technical Department.

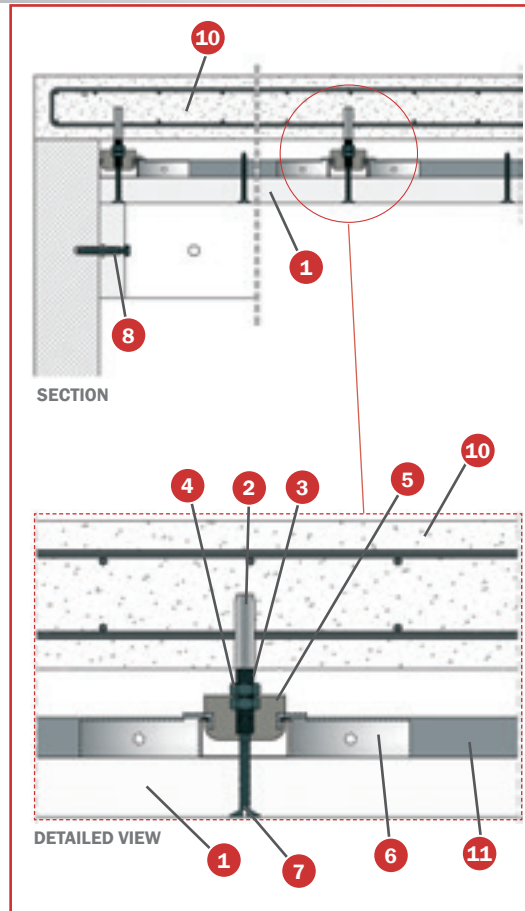

TECBOR[®]



Tunnels

7.4 TECBOR® 23 - RWS-120 TUNNEL SUSPENDED CEILING



52

TECBOR®



Tunnels

TEST

Standard: RWS.

Laboratory: TECNALIA

Test N°: 050632-002

SOLUTION

- 1 Tecbor® 23 mm boards
- 2 120 mm slab
- 3 HLC-H 8x70 mm metal plug

DESCRIPTION OF ASSEMBLY

Fix the **Tecbor®** 23 mm board directly into the concrete slab with 10x60 mm metal plug.

This system does not need any type of joint paste, although sealing with **Tecsel® mastic** is recommended for holes bigger than 3 mm.

Contact our technical department for further information.

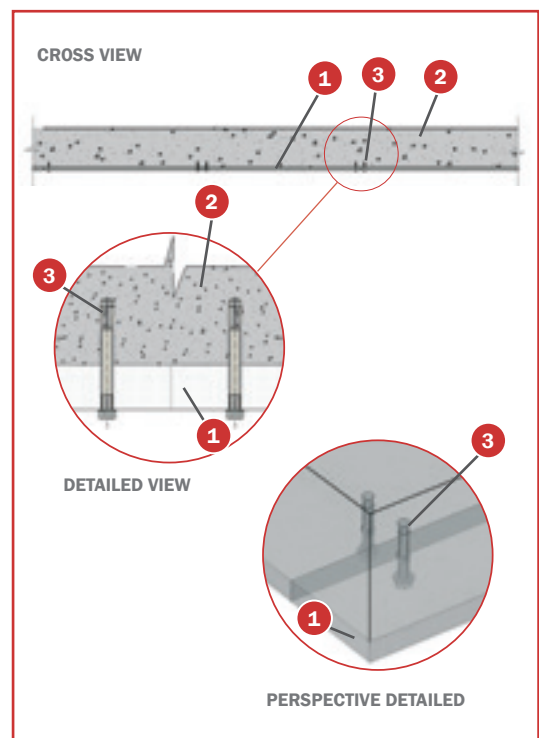

7.5 TECBOR® 24 - RABT-ZTV-170 TUNNEL SUSPENDED CEILING



TEST

Standard: RABT-ZTV.
Laboratory: EFECTIS
Test N°: R-000909

SOLUTION

- 1 Tecbor® 25 mm boards
- 2 120 mm slab
- 3 FNA II 6x30 mm metal plug

DESCRIPTION OF ASSEMBLY

Fix the **Tecbor®** 25 mm board directly into the concrete slab with 10x60 mm metal plug.

This system does not need any type of joint paste, although sealing with **Tecsel® mastic** is recommended for holes bigger than 3 mm.

Contact our technical department for further information.

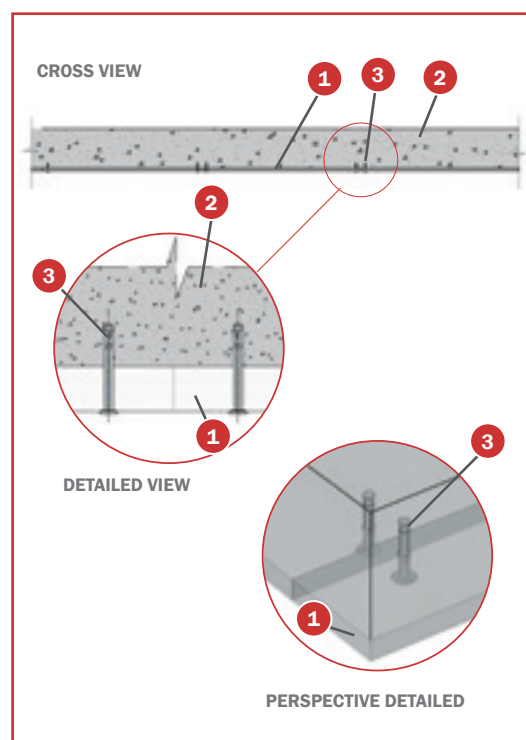

7.6 TECBOR® 24 - RWS/HCM-120 TUNNEL SUSPENDED CEILING

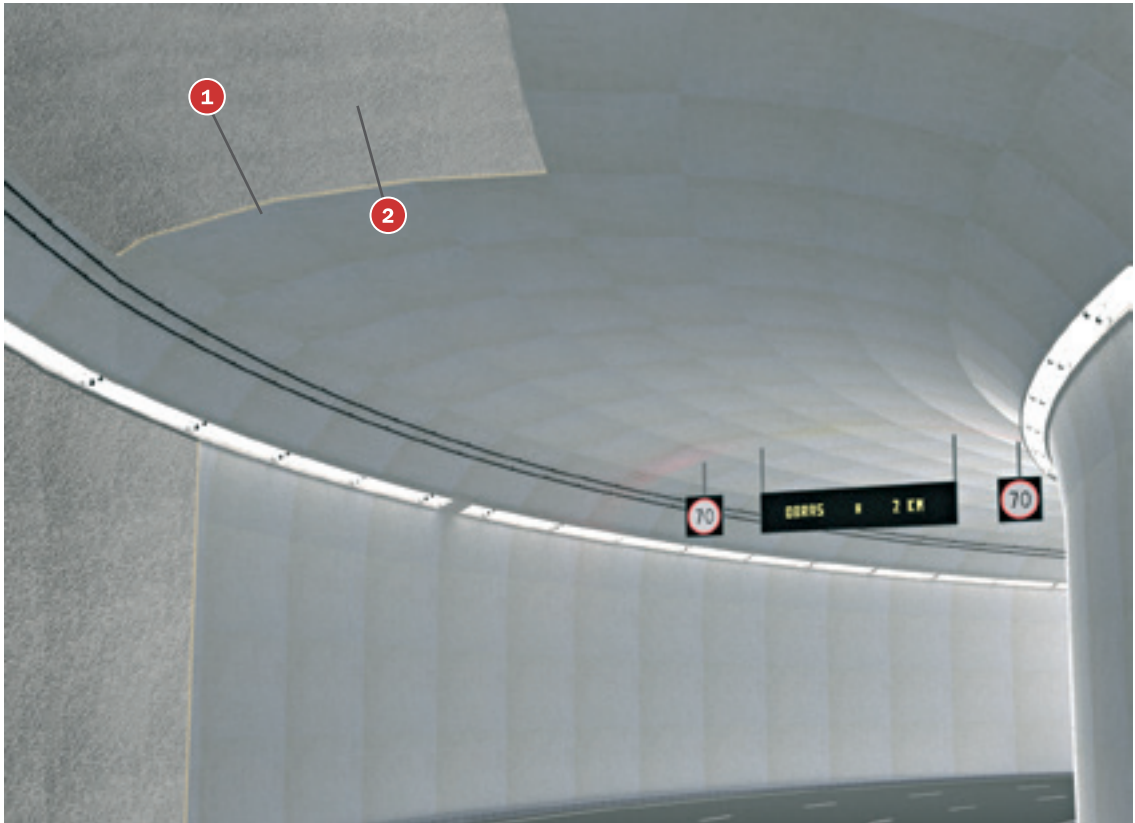

54

TECBOR®



Tunnels

TEST

Standard: RWS/HCM.

Laboratory: EFECTIS

Test N°: R-000911

SOLUTION

- 1 Tecbor® 24 mm boards
- 2 120 mm slab
- 3 Fischer FNA II 6 x 30/30 A4 metal plug

DESCRIPTION OF ASSEMBLY

Fix the **Tecbor®** 24 mm board directly into the concrete slab with 10x60 mm FNA II 6 x 30/30 A4. type Fischer metal plug.

This system does not need any type of joint paste, although sealing with **Tecsel® mastic** is recommended for holes bigger than 3 mm.

Contact our technical department for further information.

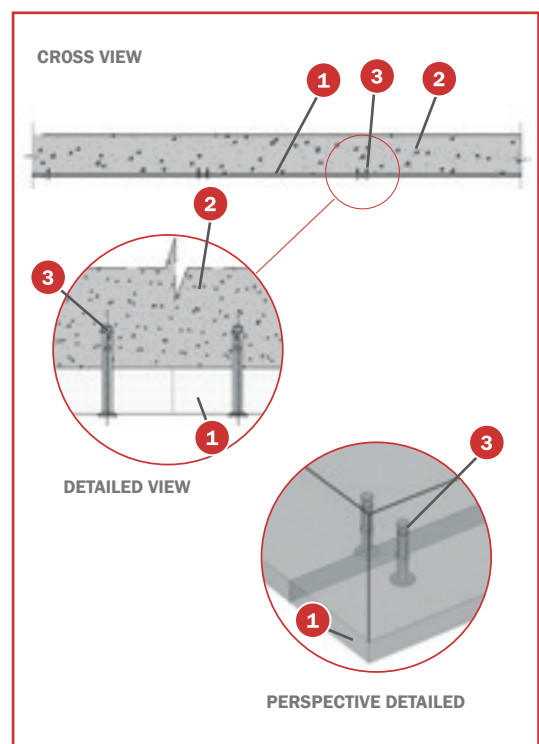

8. TECBOR® Y FIREWALL STRIPS

Spanish Royal Decree 2267/2004 on Fire Safety Regulations for Industrial Premises (RSCIEI) came into force on 3rd January 2005. The purpose of the Regulations is to provide an appropriate degree of safety in the event of fire on industrial premises.

At the point where a partition wall between buildings or industrial warehouses meets the roof, a 1-metre thick horizontal strip has to be fitted, which must have a fire resistance rating at least half that of the rating required for the wall, in order to avoid fire propagating from one warehouse or shed to adjoining warehouses or sheds.

Tecbor® Y strips consist of a bearing structure made up of square support brackets. These are fixed to the building structure (partition wall) at 1 metre spacing. The square brackets are made of struts measuring 46 x 36 x 0.6 mm.

Once the square brackets have been fitted, horse-shoe clamps measuring 45 x 15 x 0.5 mm are screwed in using 3.5 mm plate screws. These clamps are spaced 450 mm from each other.

Tecbor® Joint paste is applied at the joint between panels.

Tecsel® adhesive is used to seal the joint between the strip and the building structure.

8.1 TECBOR® Y EI-60 FIREWALL STRIPS

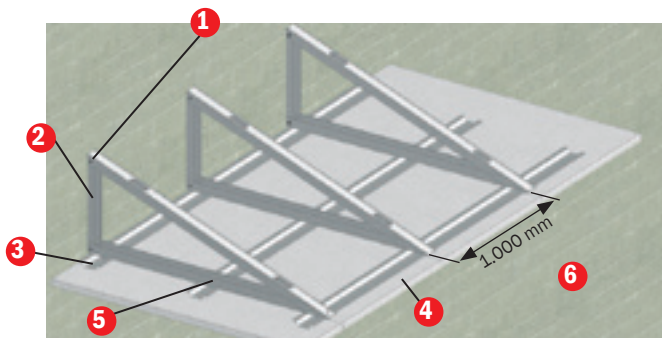

Horizontal strip installation system

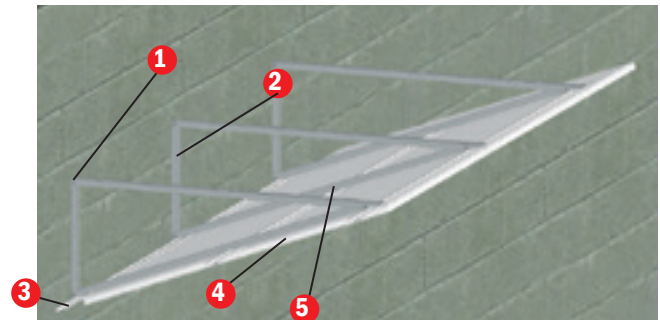

Slope strip installation system

TYPES OF STRIPS

- Attached to the **partition wall**.
- **Built directly into the roof**, when the roof has at least the same fire resistance capability as the strip..
- As an **extension of the partition wall** or as a dividing wall running 1 metre above the roof.

TEST

mercor tecresa® solutions comply with the requirements of the RSCIEI, because by covering all slope angles, they adapt and can be applied to any construction arrangement in the building.

Standard: Fire-resistance test protocol for partition wall / roof joining strips

Laboratory: TECNALIA

Test No: 052251

SOLUTION

- 1 Self-boring screw (3,5x25) mm.
- 2 Square bracket (46x36x0,6) mm.
- 3 Horse-shoe clamp (45x15x0,6) mm.
- 4 25 mm thick **Tecbor® Y** boards.
- 5 M4 countersunk screws (4x100 mm) Fischer VVR M4 with Hilti HV140 8,4/24 washer or similar.
- 6 Wall on which strip is fitted.
- 7 Wall plug and screw(10x100 mm), Hilti 50 x HRD – H 10 x 100.
- 8 **Tecbor®** joint paste.
- 9 **Tecsel®** adhesive.

DESCRIPTION OF ASSEMBLY

Slope angle on tested strip	Valid for actual installations
< 10°	0° a 25°
25°	15° a 45°
30°	20° a 50°

Horizontal strip installation system

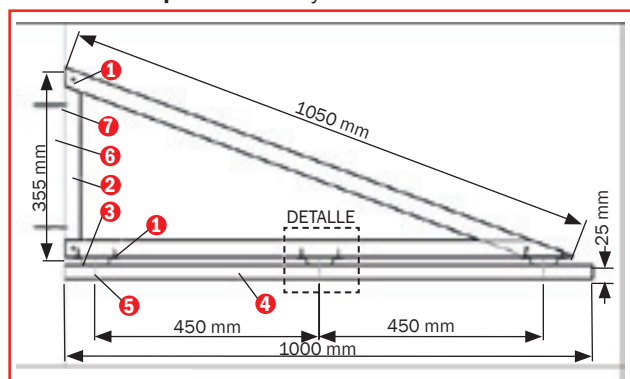

With the horizontally-fitted strip, the base-plate runs perpendicular to the wall. The 0.6 m long side of the panel rests on the wall.

Slope strip installation system

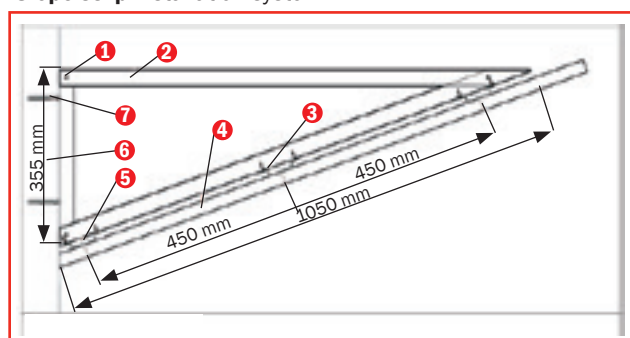

With the slope strip, the base-plate runs longitudinally and the 1 metre long side rests on the wall.



8.2 TECBOR® Y 25 + 25 mm FIREWALL STRIPS EI-120 – EI-180

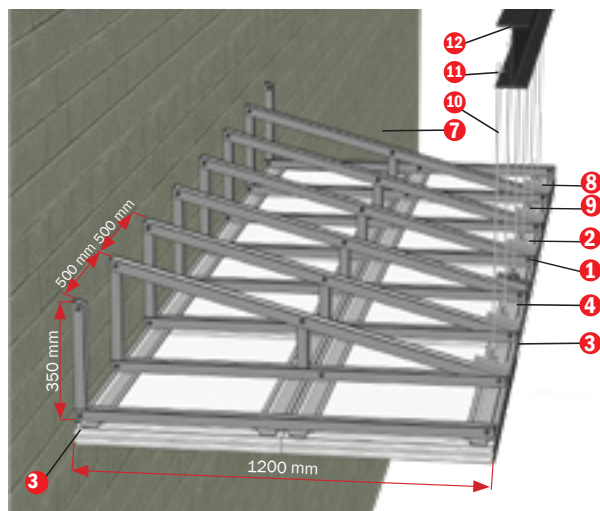

Horizontal strip installation system

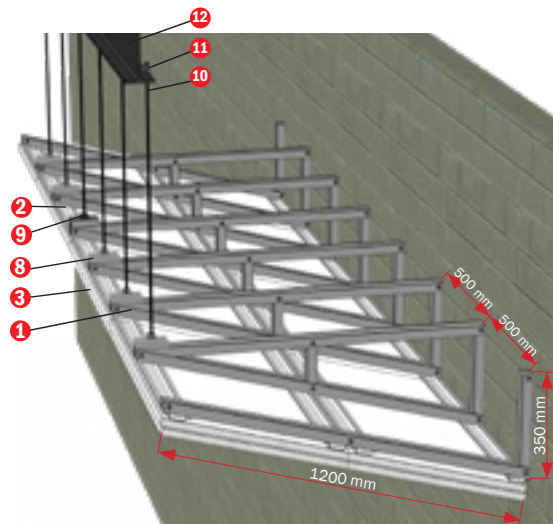

Slope strip installation system

TIPOS DE FRANJAS

- Attached to the **partition wall**.
- **Built directly into the roof**, when the roof has at least the same fire resistance capability as the strip.
- As an **extension of the partition wall** or as a dividing wall running 1 metre above the roof.

TEST

mercortecresa® solutions comply with the requirements of the RSCIEI, because by covering all slope angles, they adapt and can be applied to any construction arrangement in the building.

Standard: Fire-resistance test protocol for partition wall / roof joining strips

Laboratory: TECNALIA

Test No: 77949

SOLUTION

- 1 46x36x0,6 mm square bracket.
- 2 45x15x0,6 mm omega.
- 3 25 mm **Tecbor® Y** Board.
- 4 3,5x25 mm screws (1st layer).
- 5 3,5x65 mm screws (2nd layer).
- 6 8x80 mm wall plug and screw.
- 7 Wall on which strip is fitted.
- 8 TC 60/27.
- 9 Clip for the TC.
- 10 Threaded rod.
- 11 "Sinard" type fixing clip.
- 12 Metallic profile.



DESCRIPTION OF ASSEMBLY

Slope angle on tested strip	Valid for actual installations
< 10°	0° a 25°
25°	15° a 45°
30°	20° a 50°

Horizontal strip installation system

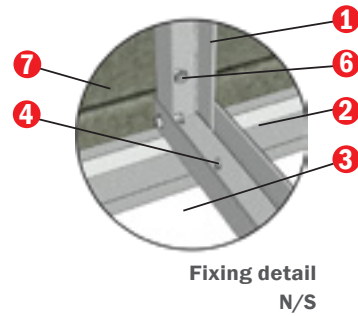
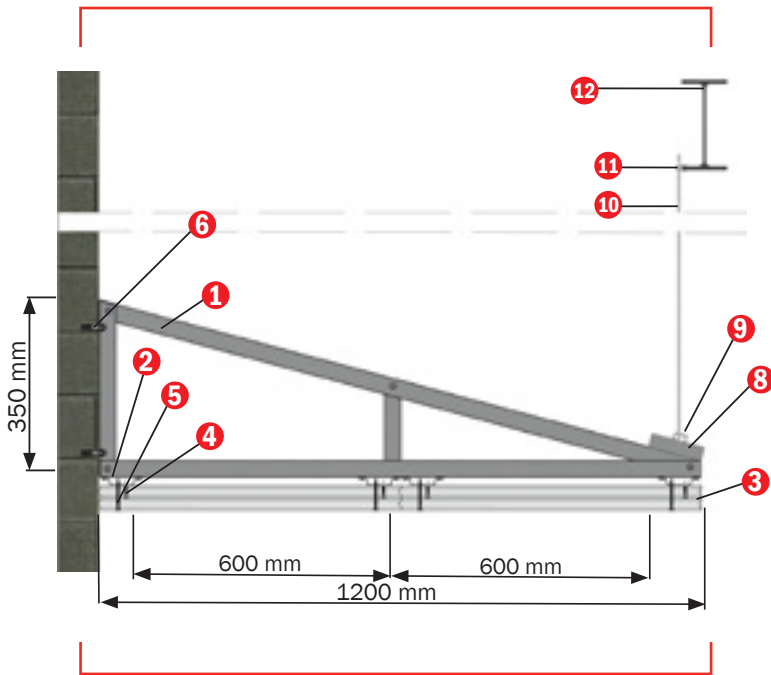

Slope strip installation system

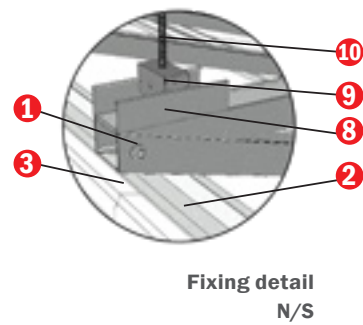
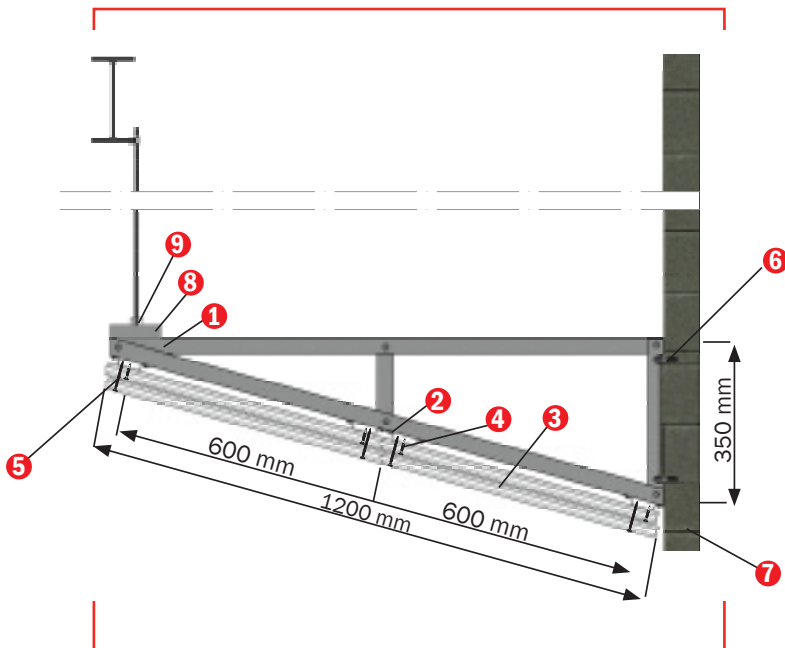

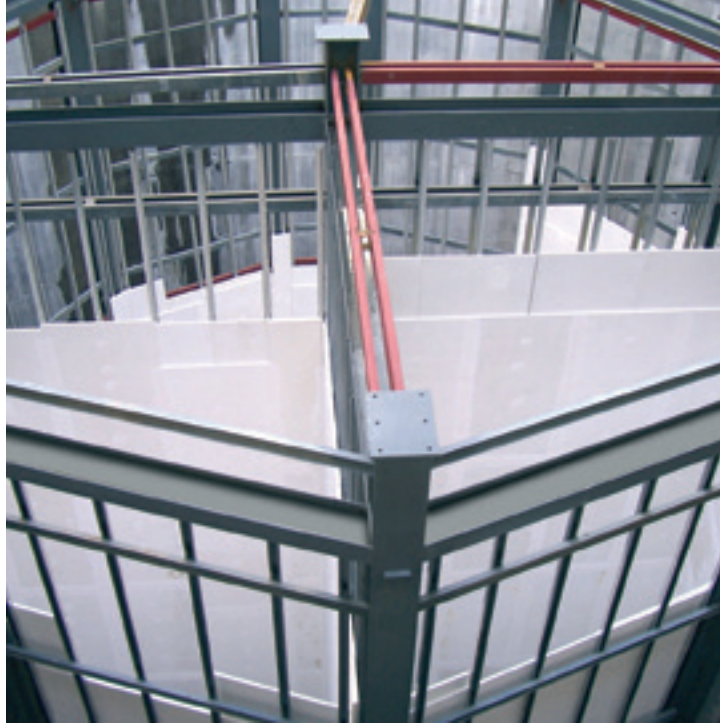

REFERENCE WORKS

- BANCO POPULAR NEW HEADQUARTERS, MADRID
- PELLI TOWER, SEVILLA
- CAIXAFORUM, SEVILLA
- UNIVERSITY AND POLYTECHNIC HOSPITAL LA FE, VALENCIA
- SERRANO TOWER, MADRID
- UNIVERSITY HOSPITAL COMPLEX, A CORUÑA
- HOSPITAL VITHAS NUESTRA SEÑORA DE LA SALUD, GRANADA
- HOSPITAL INFANTA SOFÍA, SAN SEBASTIÁN DE LOS REYES, MADRID
- HOSPITAL COMPLEX LA MANCHA CENTRO, ALCÁZAR DE SAN JUAN, CIUDAD REAL
- BANKIA, GABRIEL GARCÍA MÁRQUEZ BUILDING, LAS ROZAS, MADRID
- FERROVIAL HEADQUARTERS, C/ PRÍNCIPE DE VERGARA, MADRID
- BY-PASS M-30 NORTH AND SOUTH TUNNEL, MADRID
- XUDICIAL BUILDING, ORENSE
- CEMILFADERF SAN PEDRO MILITARY BASE, COLMENAR VIEJO, MADRID
- AVE MADRID-MURCIA: ORIHUELA-COLADA DE LA BUENA VIDA SECTION
- LINE 9 OF BARCELONA UNDERGROUND
- AVDA. DE AMÉRICA INTERCHANGE STATION, MADRID
- PRÍNCIPE PÍO INTERCHANGE STATION, MADRID
- CHAMBER OF COMMERCE PZA. DE LA INDEPENDENCIA, MADRID
- CHAMBER OF COMMERCE PALACIO DE SANTOÑA, MADRID
- ALSA BUSES MAINTENANCE WORKSHOP, MADRID-ABROÑIGAL
- PUERTO VENECIA SHOPPING CENTRE, ZARAGOZA
- MARINEDA CITY SHOPPING CENTRE, A CORUÑA
- COMEDY THEATRE, MADRID
- RIALTO THEATER, MADRID
- CANAL THEATRE, MADRID
- ETSI MINAS EN MADRID
- BRICODEPOT, MAJADAHONDA, MADRID
- LOCAL POLICE HEADQUARTERS, BOADILLA DEL MONTE, MADRID
- REAL MADRID SPORTS CITY, VALDEBEBAS, MADRID
- Pº DE LA CASTELLANA, 36-38, MADRID
- Pº DE LA CASTELLANA, 110, MADRID
- SANTA MARÍA DE LA PAZ RECEPTION CENTRE, MADRID
- MERCURE HOTEL, BURDEAUX, FRANCE
- APPLE STORE PZA. DE CATALUNYA, BARCELONA
- HOTEL JUAN CARLOS I, BARCELONA
- MERCAT DEL GUINARDÓ, BARCELONA
- VALLÉS UNDERGROUND EXTENSION FGC





www.mercortecresa.com

Headquarters

LEGATEC

Parque Leganés Tecnológico
C/Margarita Salas, 26
28919 Leganés,
MADRID
Telf: (+34) 91 428 22 60
Fax: (+34) 91 428 22 62
info@mercortecresa.com

Local Offices

CATALUÑA

Polígono Industrial "Can Ribó"
C/ Joaquim Vayreda, Nave 11
08911 Badalona,
BARCELONA
Telf: (+34) 93 464 65 00
Fax: (+34) 93 464 65 01
catalunya@mercortecresa.com

ANDALUCÍA

C/ Sevilla, 2 - 3º
14003 - Córdoba
Telf: (+34) 957 47 36 78
info@mercortecresa.com

ARAGÓN

Johann Sebastian Bach, nº 57, 2º - A
50012 Zaragoza
Telf: (+34) 616 44 00 34
Fax: (+34) 976 93 71 20
asanpelayo@mercortecresa.com